

DDRC-24

ULTRA-COMPACT 2-IN 4-OUT AUDIO PROCESSOR WITH
DIRAC LIVE® ROOM CORRECTION TECHNOLOGY



User Manual

Revision history

Revision	Description	Date
1.0	First release version	27 June 2016
1.1	Minor updates	28 June 2016
1.2	Fixing mistake in the diagram of 2.1 setup	15 July 2016
1.3	Revised installation procedure	26 July 2016
1.4	Minor update to installation procedure	15 August 2016
1.5	Simplified installation and activation procedure	17 October 2016
1.6	Revised installation procedure, updated sections related to configurations/presets	20 October 2016

CONTENTS

IMPORTANT INFORMATION.....	5
1 Product Overview.....	7
1.1 Typical Application	7
1.2 How the DDRC-24 works	8
2 Hardware connectivity	9
2.1 Digital input.....	9
2.2 Analog inputs and outputs.....	9
2.3 USB	10
2.4 DC power	10
3 Software installation	11
3.1 A note on Dirac Live license activation.....	12
3.2 Installation — Windows.....	12
3.2.1 Possible Windows installation issues.....	12
3.2.2 DDRC-24 plugin installation	12
3.2.3 Dirac Live Calibration Tool (DLCT) installation	12
3.2.4 Driver installation	13
3.3 Mac OS X installation.....	14
3.3.1 Possible Mac installation issues	14
3.3.2 DDRC-24 plugin installation	14
3.3.3 Dirac Live Calibration Tool (DLCT) installation	14
3.4 2x4 HD to DDRC-24 upgrade.....	15
4 Configuring with the DDRC-24 Plugin.....	16
4.1 Synchronizing with the processor	17
4.2 Key features	18
4.2.1 Inputs	18
4.2.2 Input selection.....	18
4.2.3 Matrix mixer.....	18
4.2.4 Outputs	19
4.2.5 Master control.....	19
4.3 Plugin configuration guide.....	20
4.3.1 Stereo room correction.....	20
4.3.2 Stereo room correction and subwoofer integration	21
4.3.3 Stereo room correction and stereo supporting woofers/FAST.....	22
4.3.4 Stereo room correction and two-way active speaker	23
5 Acoustic Measurement for Dirac Live	24
5.1 Loudspeaker and microphone positioning	24
5.2 Connections for acoustic measurement.....	25
5.3 Check your configuration/preset	26
5.4 Configuring for measurement.....	26
5.4.1 Sound System tab	27
5.4.2 Mic Config tab	27
5.4.3 Output & Levels tab.....	28
5.5 Running the measurements.....	29
5.5.1 Listening environment.....	30

- 5.5.2 Executing measurements..... 31
- 5.5.3 Viewing and redoing measurements..... 31
- 5.5.4 Completing the measurements..... 32
- 5.6 Saving and loading projects 32
- 6 Dirac Live Filter Design and Download 33
 - 6.1 Working with graphs 33
 - 6.2 Designing your target curve..... 35
 - 6.2.1 The Auto Target..... 35
 - 6.2.2 Editing the target curve 36
 - 6.2.3 Guidelines for target curve design 37
 - 6.2.4 Saving and loading target curves..... 38
 - 6.3 Generating correction filters..... 38
 - 6.4 Loading filter sets 39
- 7 Infrared remote control..... 40
- 8 USB Audio 41
 - 8.1 Mac OS X..... 41
 - 8.2 Windows..... 42
- 9 Plugin Reference 43
 - 9.1 Input channel status 43
 - 9.2 Routing 43
 - 9.3 Output channels..... 44
 - 9.3.1 Channel label..... 44
 - 9.3.2 Level metering and gain adjustment 44
 - 9.3.3 Parametric EQ..... 45
 - 9.3.4 Crossover..... 47
 - 9.3.5 Compressor 49
 - 9.3.6 Invert and mute..... 49
 - 9.3.7 Time delay..... 50
 - 9.4 Custom biquad programming 50
 - 9.4.1 What’s a “biquad? 50
 - 9.4.2 Using custom biquad programming 51
 - 9.4.3 Biquad design software..... 52
 - 9.5 Working with configurations 53
 - 9.5.1 Online and offline mode 53
 - 9.5.2 Selecting a configuration 53
 - 9.5.3 Saving and loading configurations..... 54
 - 9.5.4 Relationship with Dirac Live 54
 - 9.5.5 Restoring to defaults..... 55
 - 9.6 Keyboard shortcuts 55
- 10 Additional Information 56
 - 10.1 Specifications 56
 - 10.2 Firmware upgrade..... 57
 - 10.2.1 Windows 57
 - 10.2.2 Mac OS X 59
 - 10.3 Troubleshooting 60
 - 10.4 Obtaining support 61



IMPORTANT INFORMATION

Please read the following information before use. In case of any questions, please contact miniDSP via the support portal at minidsp.desk.com.

System Requirements

To configure the miniDSP audio processor, you will require a Windows PC or Apple Mac OS X computer with the following minimum specification:

Windows

- Intel Pentium III or later, AMD Athlon XP or later
- 2 Gigabytes (GB) of RAM or higher
- Keyboard and mouse or compatible pointing device
- Microsoft® Windows® Vista® SP1/Win7/Win8/Win10
- Two free USB 2.0 ports

Mac OS X

- Intel-based Mac with 1 GHz or higher processor clock speed
- 2 Gigabytes (GB) of RAM or higher
- Keyboard and mouse or compatible pointing device
- OS X 10.9 (Mavericks) to macOS 10.12 (Sierra)
- Two free USB 2.0 ports

Disclaimer/Warning

miniDSP cannot be held responsible for any damage that may result from the improper use of this product or incorrect configuration of its settings. As with any other product, we recommend that you carefully read this manual and other technical notes to ensure that you fully understand how to operate this product. The miniDSP audio processor is a powerful tool, and misuse or misconfiguration, such as incorrectly set gains or excessive boost, can produce signals that may damage your audio system.

As a general guideline, you should perform the initial configuration of the miniDSP audio processor before enabling audio through any connected output device or amplification. Doing so will help ensure that the software is correctly configured.

Finally, note that the miniDSP audio processor is a very flexible device, and many of the questions we receive at the tech support department are already answered in this user manual and in the online [application notes](#) on the miniDSP.com website. So please take the time to carefully read this user manual and the online technical support. Thanks for your understanding!

Warranty Terms

miniDSP Ltd warrants this product to be free from defects in materials and workmanship for a period of one year from the invoice date. Our warranty does not cover failure of the product due to incorrect connection or



installation, improper or undocumented use, unauthorized servicing, modification or alteration of the unit in any way, or any usage outside of that recommended in this manual. If in doubt, contact miniDSP prior to use.

FCC Class B Statement

This device complies with Part 15 of the FCC Rules. Operation is subject to the following two conditions:

- This device may not cause harmful interference.
- This device must accept any interference received, including interference that may cause undesired operation.

Warning: This equipment has been tested and found to comply with the limits for a Class B digital device, pursuant to Part 15 of the FCC Rules. These limits are designed to provide reasonable protection. This equipment generates, uses and can radiate radio frequency energy and, if not installed and used in accordance with the instructions, may cause interference to radio communications. However, there is no guarantee that interference will not occur in a particular installation. If this equipment does cause harmful interference to radio or television reception, which can be determined by turning the equipment off and on, the user is encouraged to try to correct the interference by one or more of the following measures:

- Reorient or relocate the receiving antenna.
- Increase the separation between the equipment and receiver.
- Connect the equipment into an outlet on a circuit different from that to which the receiver is connected.
- Consult the dealer or an experienced radio/TV technician for help.

Notice: Shielded interface cable must be used in order to comply with emission limits.

Notice: Changes or modification not expressly approved by the party responsible for compliance could void the user’s authority to operate the equipment.

CE Mark Statement

The DDRC-24 has passed the test performed according to European Standard EN 55022 Class B.

A note on this manual

This User Manual is designed for reading in both print and on the computer. If printing the manual, please print double-sided. The embedded page size is 8 ½” x 11”. Printing on A4 paper will result in a slightly reduced size.

For reading on the computer, we have included hyperlinked cross-references throughout the manual. In addition, a table of contents is embedded in the PDF file. Use the View menu (Preview on Mac) or the bookmarks sidebar (Adobe reader on Mac and Windows) to view this table of contents.

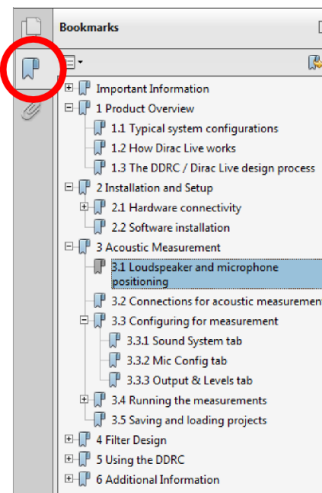

Adobe Reader on Windows

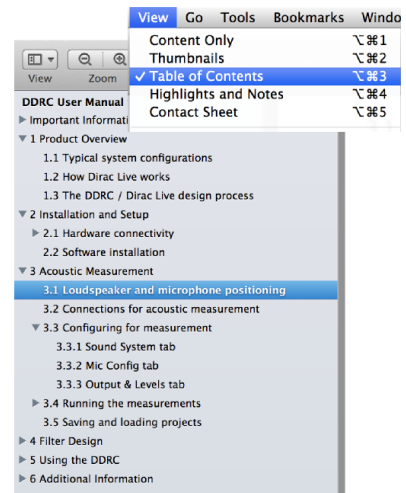

Preview on Mac

1 PRODUCT OVERVIEW

Thank you for purchasing a miniDSP DDRC-24 audio processor powered by Dirac Live®, the world’s premier room correction solution. We are delighted to offer you this extremely compact yet powerful software and hardware combination, the fruit of extensive research and development and years of experience in sound system tuning.

The miniDSP DDRC-24 offers not only a two-channel Dirac Live® room correction processor, but also an input-output matrix mixer and a powerful set of DSP audio processing functions on each output channel. This allows the DDRC-24 to be used for correction of a stereo signal, integration of one or two subwoofers, or to implement a combined two-way crossover and room correction processor. Combined with its selection of analog, optical digital, and asynchronous USB (up to 192 kHz) inputs, the miniDSP DDRC-24 offers an unprecedented level of audio processing performance for its size and price bracket.

1.1 TYPICAL APPLICATION

In the typical application shown below, the miniDSP DDRC-24 acts as preamp and room correction/subwoofer integration processor. Volume control is accomplished with a remote control by using the DDRC-24’s remote learning feature.

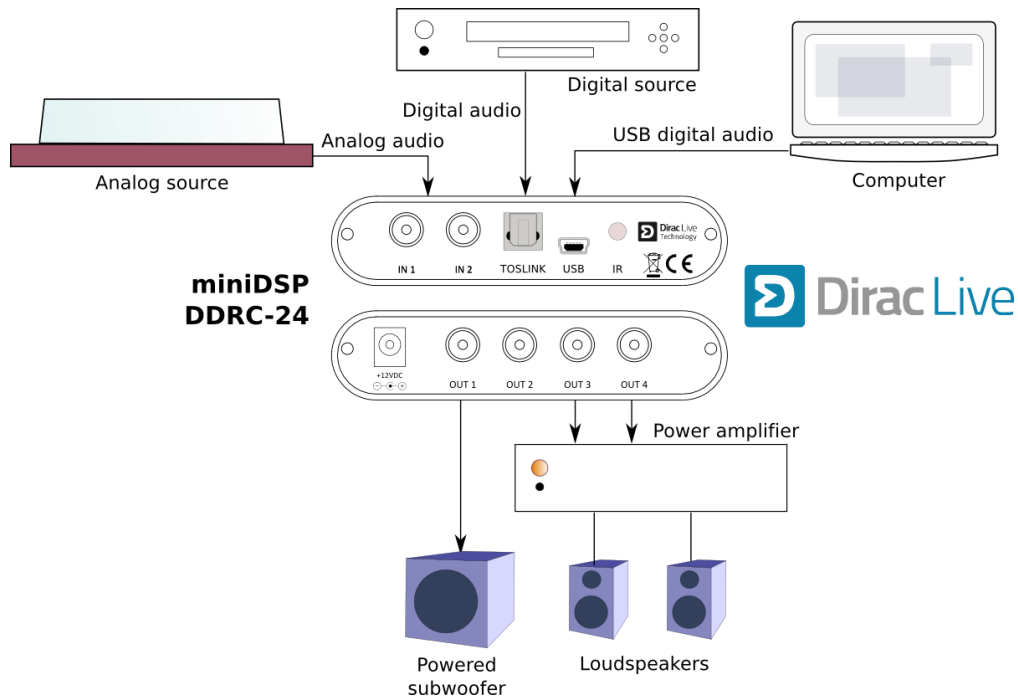

Many other system configurations are possible with the miniDSP DDRC-24. See the [Plugin configuration guide](#) (pages 20 to 23) for examples.

1.2 HOW THE DDRC-24 WORKS

The processing of the ground-breaking miniDSP DDRC-24 is best described in terms of a signal flow diagram:

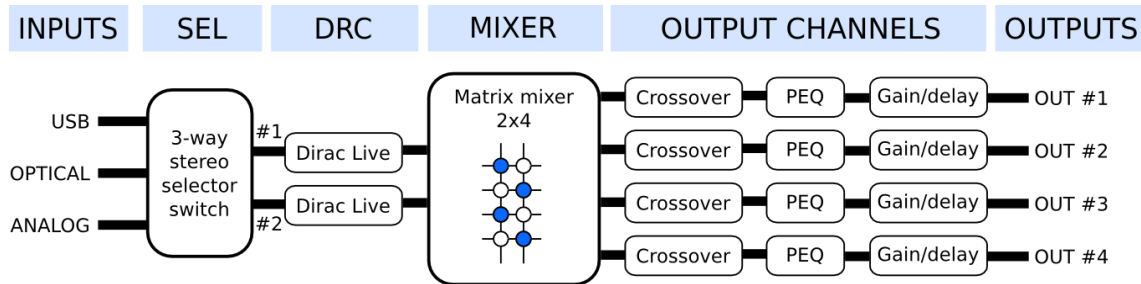

One of the three stereo input sources is selected by the user and passed to the Dirac Live processing blocks, which implement digital room correction (DRC). The Dirac Live outputs are fed into a 2-in 4-out matrix mixer. The matrix mixer is what enables the DDRC-24 to be used in a number of different application scenarios.

The outputs from the mixer are processed through a comprehensive set of DSP functions – crossover filters (high pass and low pass), parametric EQ, and individual gain and delay adjustments. These are all optional – you can configure them if you want to, according to your particular application. Finally, the four output channels are converted to analog so they can be fed to your power amps or to your subwoofer(s).

While the description of the signal processing flow is from inputs to outputs (left to right in the diagram), the order in which you configure the DDRC-24 is basically the reverse. Because Dirac Live measures everything in the diagram that comes “after” it (including the speakers and room), the matrix mixer and output channel processing need to be set up **before** running a Dirac Live calibration. This configuration is done with the DDRC-24 plugin, described with concise examples in Section 4 and in full detail in Section 9.

Once you have set up the mixer and output channel processing, quit the DDRC-24 plugin and start Dirac Live Calibration Tool for miniDSP (DLCT). This program executes the measurement and optimization regime from Dirac Research that is used to generate the Dirac Live room correction filters. There are three key steps.

1. Measure the response of your room in nine different locations (Section 5).
2. Set up a target curve (Section 6). You use this to generate customized corrected responses to suit your system, room, and preferences.
3. Create optimized correction filters and load them onto the DDRC-24 (page 39). You can load up to four sets of correction filters with different target curves.

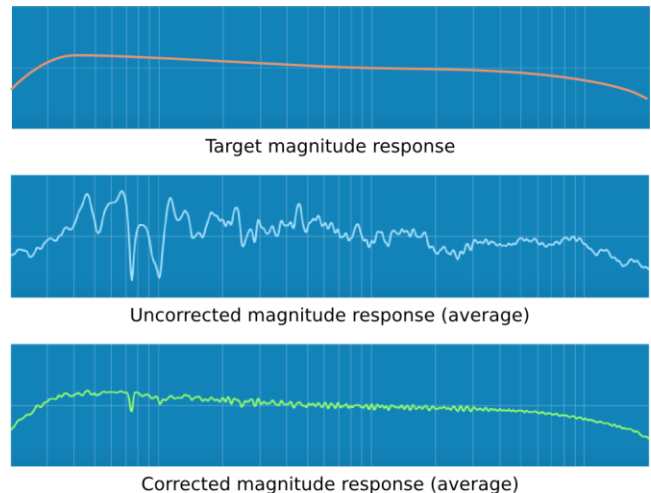

With that all done, program a remote control and sit back and enjoy the fruits of your labor! Dirac Live’s mixed-phase filtering technology will improve the imaging and clarity of your system, minimize the effects of room modes and resonances, and improve dynamics and clarity.

2 HARDWARE CONNECTIVITY

2.1 DIGITAL INPUT

Connect a single digital source to the optical (TOSLINK) connector. Thanks to its asynchronous sample rate convertor (ASRC), all sample rates between 44.1 and 192 kHz are accepted.

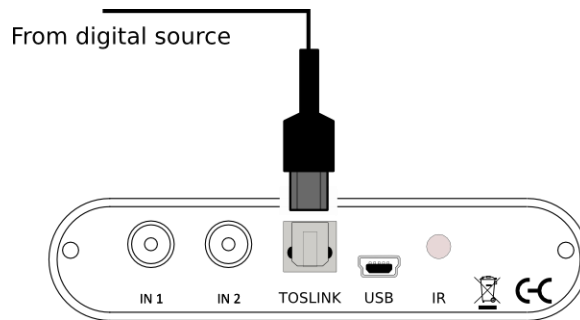

Note: the digital input accepts only a stereo PCM digital signal. It does not accept encoded or multichannel digital audio (such as Dolby Digital or DTS).

2.2 ANALOG INPUTS AND OUTPUTS

Connect an analog source or preamplifier to the RCA connectors on the front panel, and connect the four analog outputs to power amplification or subwoofer(s). Be sure to take careful note of the channel numbering shown in this diagram and on the rear panel.

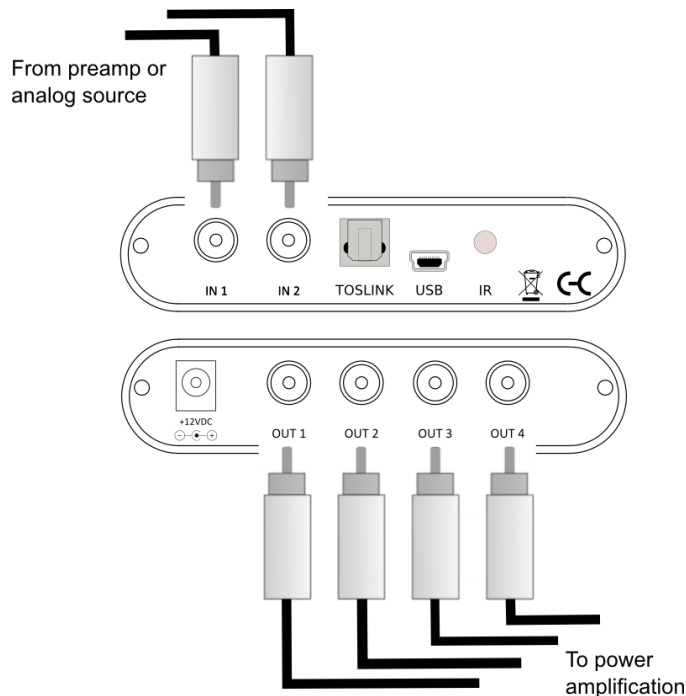

2.3 USB

Connect the USB (Type B mini) port of the DDRC-24 to a free USB 2.0 port of your computer using the supplied cable. The USB connection is used for:

- Configuration with the DDRC-24 plugin and Dirac Live Calibration Tool for miniDSP, and
- Streaming audio from a computer or other device such as a music streamer, at up to 192 kHz.

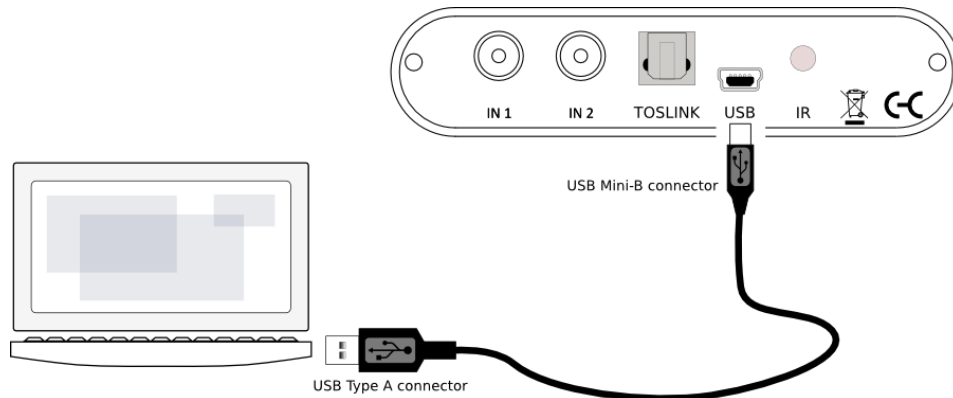

2.4 DC POWER

The supplied 12 VDC power supply includes a set of interchangeable power pins (for USA, UK, Europe and Australia). Fit the correct pins for your country. Connect the DC plug to the 12 VDC power socket.

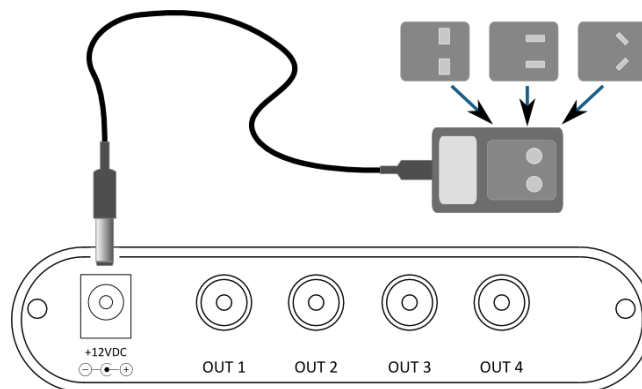

Apply power to the processor only after all input and output connections have been made. The processor uses very little power and so can be left powered on. If powered on and off, the following sequence is always recommended:

- On: Power on line-level equipment, including the DDRC-24, then turn on power amplification.
- Off: Turn power amplification off, then power off line-level equipment, including the DDRC-24.

3 SOFTWARE INSTALLATION

If you purchased your product directly from miniDSP, your software will be available from the [User Downloads](#) section of the miniDSP website when your order ships. You will need to be logged into the website with the account you created when purchasing to access the download.

If you purchased your product from a miniDSP dealer, you will receive a coupon together with the product. Redeem this coupon and select the Plugin Group “Dirac Series” at the link below:

- <https://www.minidsp.com/support/redeem-coupon>

The User Downloads link is visible from the dropdown menu at the top right of the website page:

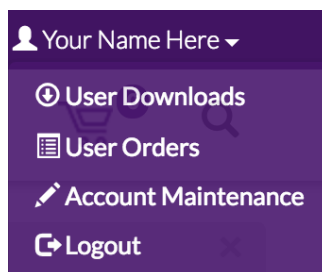

Navigate to the **Dirac Series** section and then to **DDRC-24 Software**. There you will find a single download containing all software. Download this file and unzip it (on Windows, right-click and select “Extract All...”; on Mac, double-click). The unzipped download has a name like **DDRC_24_102a** and will contain the following folders:

Dirac Live

This folder contains the installers for **Dirac Live Calibration Tool for miniDSP (DLCT)** stereo version, which is used to perform the Dirac Live calibration, including taking measurements, generating correction filters, and loading them into the DDRC-24. There are separate Windows and Mac versions.

Plugins

This folder contains the installers for the **DDRC-24 plugin**, used to set up non-Dirac signal processing, configure remote control codes and perform various other maintenance operations on the DDRC-24. There are separate Windows and Mac versions.

WinDrivers

This folder contains the installers for the drivers that must be installed on Windows to allow the above software programs to communicate with the **DDRC-24** hardware. It also enables USB audio streaming from the computer. *To use the DDRC-24 with Windows, this driver **must** be installed.*

XMOS_Firmware

This folder contains the firmware for the DDRC-24. miniDSP may occasionally provide updated firmware to improve functionality and performance – see [Firmware upgrade](#) starting on page 57 for the upgrade procedure. It is also installed if performing an upgrade from the 2x4 HD to the DDRC-24 – see [2x4 HD to DDRC-24 upgrade](#) on page 15 for more information.

3.1 A NOTE ON DIRAC LIVE LICENSE ACTIVATION

As of version 1.2.0 of Dirac Live Calibration Tool, license activation is done automatically when DLCT recognizes a valid Dirac Live license code in the hardware unit itself. No separate manual activation step is required.

If you have previously used a miniDSP Dirac Live product and used the manual license activation process, be aware that this is no longer necessary. Note also that automatic license activation will apply to all miniDSP Dirac Live units in the field.

The only exception to this is units that were purchased as a miniDSP2x4 HD and are subsequently being upgraded to Dirac Live. In that case, see Section 3.4.

3.2 INSTALLATION — WINDOWS

3.2.1 Possible Windows installation issues

The miniDSP software requires that a number of other frameworks be installed for it to work. For Windows 7 and later, these packages should be installed automatically. For earlier versions of Windows, please download and install the following frameworks before attempting to install any miniDSP software. You can also manually install these if you receive an error message that required software is missing.

- [Microsoft .NET framework](#) (version 3.5 or later)
- Latest version of [Adobe Air](#)
- Microsoft Visual C++ 2010 Redistributable Package: for [x86](#) (32-bit operating system) or [x64](#) (64-bit operating system).

3.2.2 DDRC-24 plugin installation

1. Navigate to the **Plugins** folder of the software download.
2. Double-click on the **DDRC_24.exe** installer program to run it. We recommend that you accept the default installation settings.

3.2.3 Dirac Live Calibration Tool (DLCT) installation

1. Navigate to the **Dirac Live** folder of the software download and then to the **Windows** folder.
2. Double-click on the installer to run it. You may need to unzip it first (right-click, then select “Extract All”). The installer will have a name similar to **Dirac Live Calibration Tool for DDRC-2x v1.2.0.8344 Setup.exe** (the version number starting with v1.2... may be different). We recommend that you accept the default installation settings. However, on the last screen, uncheck the box to start Dirac Live automatically (you will need to install the driver as described on the next page before using DLCT).

Completing Dirac Live Calibration Tool Setup

Dirac Live Calibration Tool has been installed on your computer.

Click Finish to close Setup.

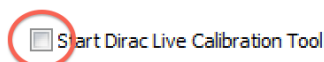

3.2.4 Driver installation

1. Connect the DDRC-24 to the computer using the supplied USB cable, and power it on.
2. Navigate to the **WinDrivers** folder of the software download and double-click on the appropriate installer:
 - **miniDSP_UAC2_v2.29.0_ForWinXP_Vista.exe** for Windows XP and Vista
 - **miniDSP_UAC2_v3.34.0_ForWin7_8_10.exe** for Windows 7, 8, and 10

(The version number embedded in the filename may be different.)

We recommend accepting the default installation location. Once the driver installation completes, click the **Finish** button.



The Windows PC will not be able to communicate properly with the DDRC-24 if you did not have the DDRC-24 connected by USB and powered on when you installed the driver. If that is the case, you will need to uninstall the driver, connect the DDRC-24, power it on, and run the installer again.

Note: the first time you run DLCT, you may see a warning from Windows Firewall as shown below. If so, ensure that “Private networks...” is checked and “Public networks...” is not checked. Then click on “Allow access.”

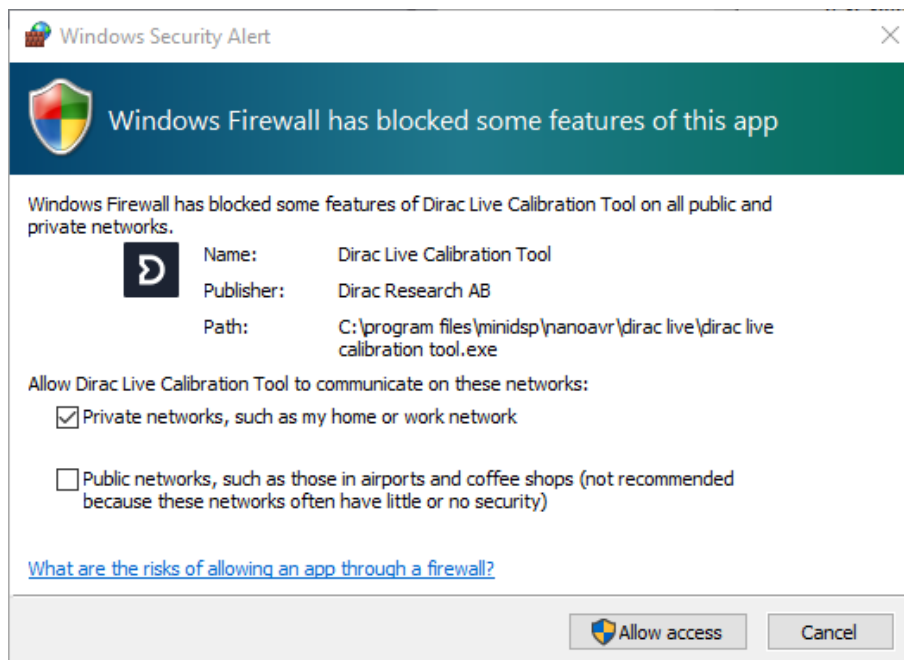

3.3 MAC OS X INSTALLATION

3.3.1 Possible Mac installation issues

If double-clicking on an installer brings up a message that the installer cannot run, use this alternate method:

1. Right-click on the installer (or click while holding the Control key).
2. On the menu that pops up, move the mouse over the “Open With” item and then click on “Installer (default).”

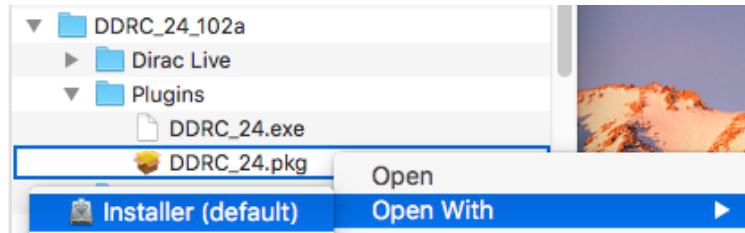

3. The following window will appear. Click on “Open.”

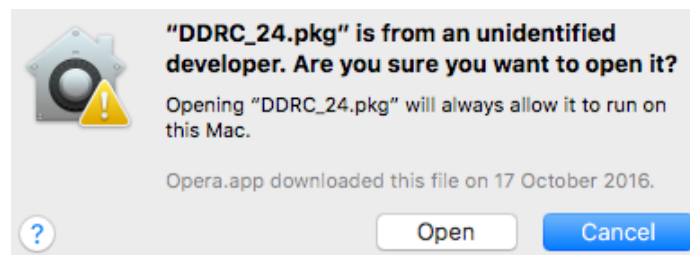

3.3.2 DDRC-24 plugin installation

3. Navigate to the **Plugins** folder of the software download.
4. The installer program is named **DDRC_24.pkg**. To run it, double-click on it, or right-click and open as described above. We recommend that you accept the default installation settings.
5. To run the DDRC-24 plugin, locate **DDRC-24.app** in the Applications -> miniDSP folder and double-click on it. To make it easier to run in future, right-click on its dock icon and select Options -> Keep in Dock.

3.3.3 Dirac Live Calibration Tool (DLCT) installation

1. Navigate to the **Dirac Live** folder of the software download and then to the **Mac** folder.
2. The installer program will have a name similar to **Dirac Live Calibration Tool for DDRC-2x v1.2.0.8392.mpkg** (the version number starting with v1.2... may be different). To run it, double-click on it, or right-click and open as described above. You may need to double-click twice (the first time to extract it, the second time will run it). We recommend that you accept the default installation settings.
3. To run DLCT, locate **Dirac Live Calibration Tool.app** in the Applications -> miniDSP folder and double-click on it. To make it easier to run in future, right-click on its dock icon and select Options -> Keep in Dock.

4 CONFIGURING WITH THE DDRC-24 PLUGIN

The DDRC-24 processor is configured with the **DDRC-24** plugin / user interface program. Configuration of the DDRC-24 using the plugin must be done prior to performing Dirac Live calibration. This section provides a summary of the plugin and how to use it.



During *initial* configuration of the processor, it is strongly recommended that any connected amplification be powered off.

Upon starting the plugin, it brings up a screen with various controls and a main configuration area:

Annotations on the screenshot:

- Main menu:** Points to the menu bar (File, Restore, Help, IR Remote).
- Configuration selection:** Points to the 'Configuration Selection' area with buttons for Config 1, Config 2, Config 3, and Config 4.
- Selection tab:** Points to the 'Routing' and 'Outputs' tabs.
- Main configuration window:** Points to the main content area containing Dirac Inputs and Routing.
- Master control:** Points to the 'Connect', 'Mute', 'Master Volume', and 'Dirac Live OFF' controls.

	Output1	Output2	Output3	Output4
Dirac 1	0dB	0dB	Off	Off
Dirac 2	Off	Off	0dB	0dB

This section describes the key features of the plugin and provides an application-specific guide to configuring it. For detailed information about each of the plugin's features, see Section 9.

4.1 SYNCHRONIZING WITH THE PROCESSOR

Connect the DDRC-24 to a USB 2.0 port on your computer. Then click on the **Connect** button:



If successful, the button changes to a green tick as shown above. For the sake of brevity, this state is referred to as “online” whereas the earlier state with the circular arrows is referred to as “offline.” When the plugin is online, any changes made in the DDRC-24 plugin are immediately transferred to the DDRC-24 and will be heard in the audio signal.

The first time you connect, or if you have made any changes to any data in the plugin, a dialog box will appear:

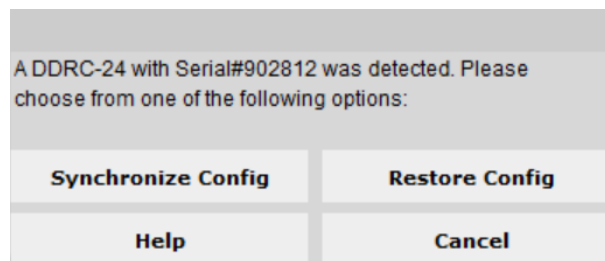

Restore ALL to default

This option will appear the very first time you connect. It is strongly recommended that you select this option the first time. After restoring all data to defaults, the plugin is online.

Synchronize Config

Download the data for the currently selected configuration into the DDRC-24. Note that this applies only to data that can be changed in the DDRC-24 plugin — Dirac Live filters are not changed by doing this. After downloading the configuration data, the plugin is online.

Synchronize and Upgrade

This is similar to Synchronize Config, but also upgrades the internal data of the processor. This option may appear after downloading and installing an updated version of the plugin.

Restore Config

Restore the data in the currently selected configuration to the factory defaults. Note that this applies only to data that can be changed in the DDRC-24 plugin — Dirac Live filters are not changed by doing this. When using this option, any connected equipment should be muted or powered off until you have set the configuration to a working state. Configuration data will be lost, so if needed, ensure that you have saved the configuration to a file prior to using this option. After restoring, the plugin is online.

Help

This option brings up a help screen explaining the options.

Cancel

This option cancels the attempt to connect to the processor. The plugin will remain offline.

4.2 KEY FEATURES

4.2.1 Inputs

The **Routing** tab displays two input channel status strips. Note that these are status only – there are no user-adjustable controls. They are active only when the plugin is online. For more information, see page 43.

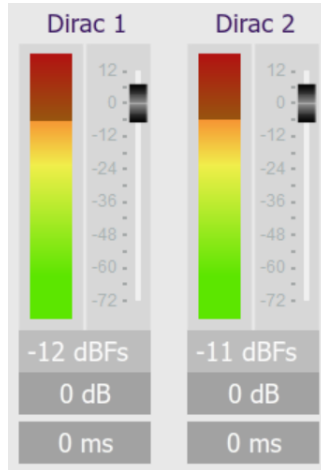

4.2.2 Input selection

When the plugin is online, the currently selected input appears next to the “Dirac Inputs” label. Click on the current input name to drop down a selector menu, from which you can select a different input. The input can also be selected with a remote control – see page 40.

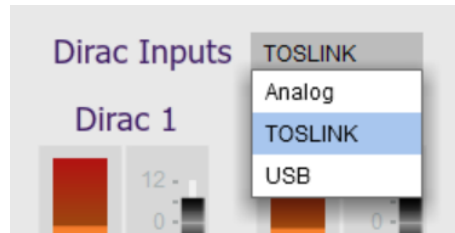

4.2.3 Matrix mixer

The matrix mixer on the Routing tab directs input channels (along the left) to output channels (along the top). To turn on routing for a cross point, click on that cross point. Both inputs can be mixed to each output if desired, and the mix level can be set individually for each input. For more information, see page 43.

	Output1	Output2	Output3	Output4
Dirac 1	0dB	0dB	Off	Off
Dirac 2	Off	Off	0dB	0dB

4.2.4 Outputs

The **Outputs** tab displays a row of four output channel control strips. All output channels are identical.

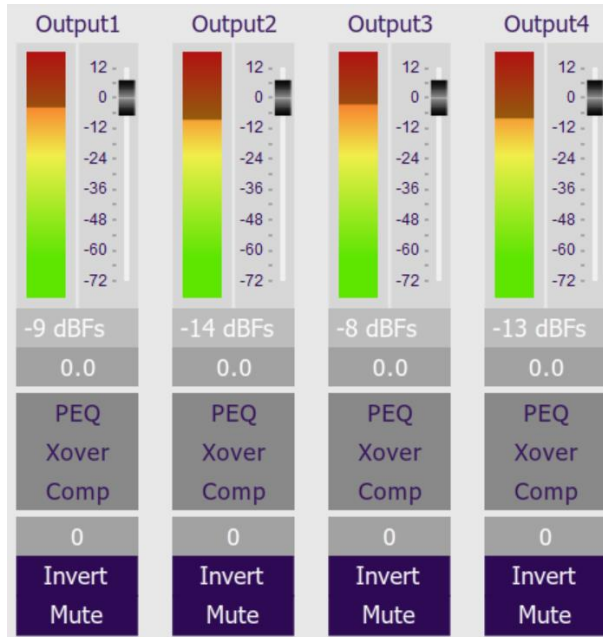

Each channel has an individual gain adjustment slider, and a graphical and numerical display of the current signal level on that channel.

A comprehensive set of signal processing functions is accessed with the buttons PEQ, Xover, and Comp. Each channel also has individual invert and mute controls, and a signal delay of up to 30 ms. These are described in detail in Section 9.

4.2.5 Master control

Once the plugin is online, the items in the Master Control area are active. The **Mute** button disables all audio output:



The **Master Volume** display shows the current volume setting. The master volume can be set directly by clicking here and typing a new value. It can also be set with a remote control or from within DLCT:

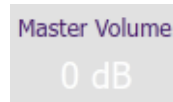

The **Dirac Live** button turns Dirac Live processing on and off. This function can also be accessed with a remote control and from within DLCT:



4.3 PLUGIN CONFIGURATION GUIDE

The miniDSP DDRC-24 is adaptable to many system configurations. This section gives examples of several common system types and shows how to configure the DDRC-24 plugin for each. For full details of the referenced signal processing blocks, see Section 9.

4.3.1 Stereo room correction

In a stereo room correction configuration, the plugin is set up to route the selected input through to output channels 1 and 2. This diagram illustrates the connections:

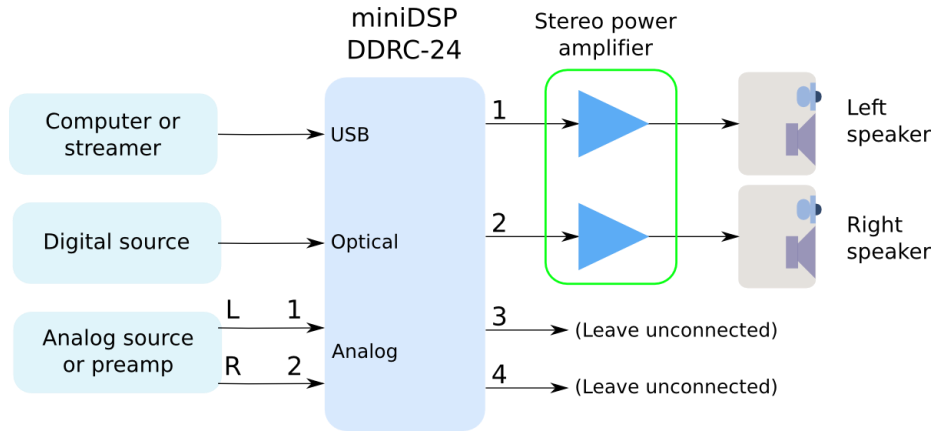

On the **Outputs** tab:

- Rename the output channels (from left to right) to “Left”, “Right”, “Unused” and “Unused”.
- Mute channels 3 and 4 (labeled “Unused”).
- Check that the crossover filters of channels 1 and 2 (“Left” and “Right”) are set to Bypass:



On the **Routing** tab, set the matrix like this:

	Left	Right	Unused	Unused
Dirac 1	0dB	Off	Off	Off
Dirac 2	Off	0dB	Off	Off

After you have set up the DDRC-24 plugin, save your configuration to a file. Then quit the DDRC-24 plugin, start Dirac Live Calibration Tool, and run the Dirac Live calibration as described in sections 5 and 6.

4.3.2 Stereo room correction and subwoofer integration

In a stereo room correction with subwoofer integration configuration, the plugin is set up to route low frequencies from the left and right inputs to a single subwoofer output. This diagram illustrates the connections:

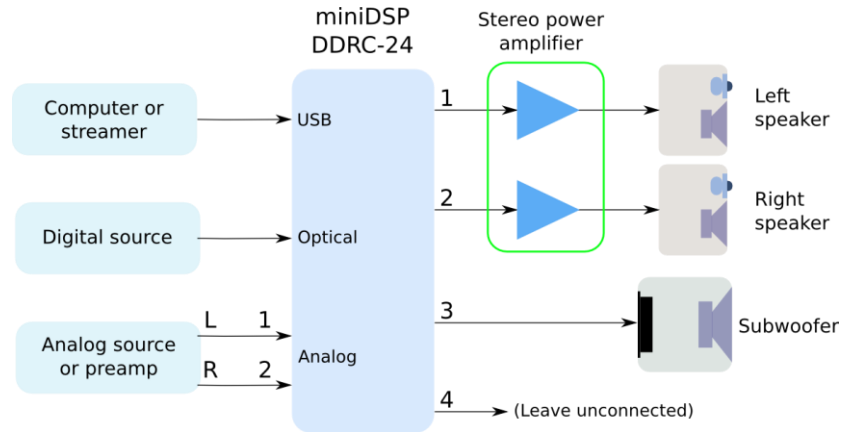

On the **Outputs** tab:

- Rename the output channels (from left to right) to “Left Sp”, “Right Sp”, “Subwoof” and “Unused”.
- Mute channel 4 (“Unused”).
- Set a high pass crossover filter on channels 1 and 2 (“Left Sp” and “Right Sp”). For example:

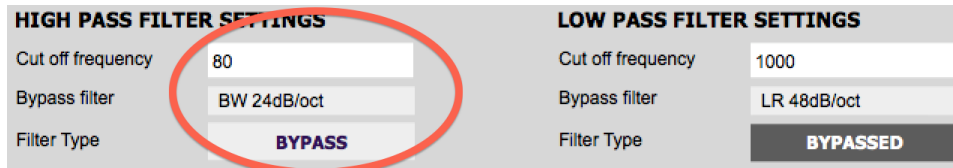

- Set a low pass crossover filter on channel 3 (“Subwoof”). For example:

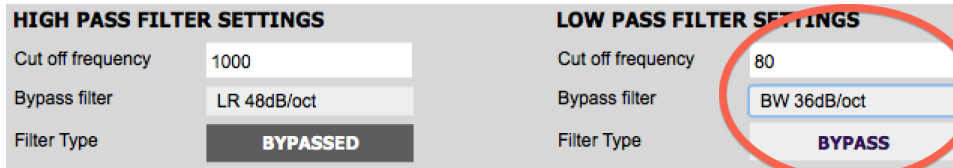

On the **Routing** tab, set the matrix like this:

	Left Sp	Right Sp	Sub	unused
Dirac 1	0dB	Off	0dB	Off
Dirac 2	Off	0dB	0dB	Off

You may need to do measurements with Room EQ Wizard (or a similar program) to fine-tune your subwoofer crossover settings, as described in our DDRC-24 Sub integration note [at this link](#). After you have set up the DDRC-24 plugin, save your configuration to a file. Then quit the DDRC-24 plugin, start Dirac Live Calibration Tool, and run a Dirac Live calibration as described in sections 5 and 6.

4.3.3 Stereo room correction and stereo supporting woofers/FAST

In a configuration with two full range speakers supplemented by supporting woofers (sometimes known as “FAST”), the plugin is set up to split the frequency range to the woofer and full range speakers. This diagram illustrates the connections:

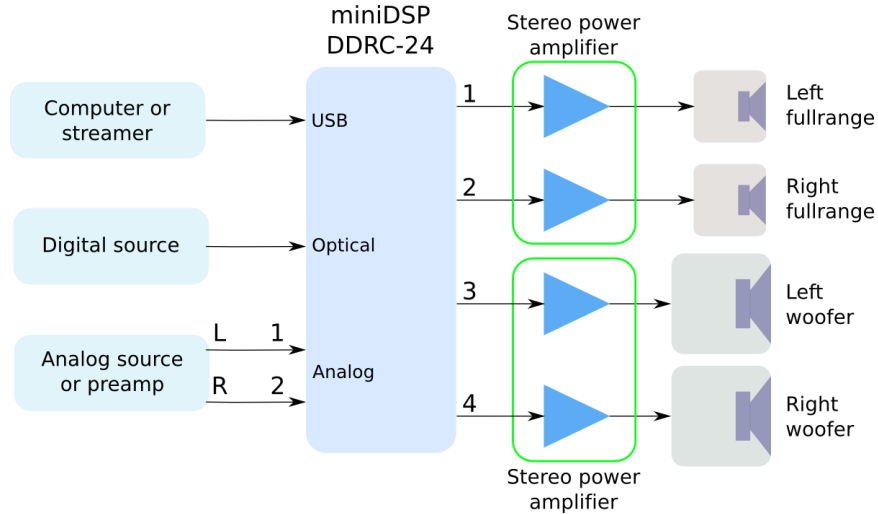

On the **Outputs** tab:

- Rename the output channels (from left to right) to “Left FR”, “Right FR”, “Left W” and “Right W”.
- Set a high pass crossover filter on channels 1 and 2 (“Left FR” and “Right FR”). For example:



- Set a low pass crossover filter on channels 3 and 4 (“Left W” and “Right W”). For example:

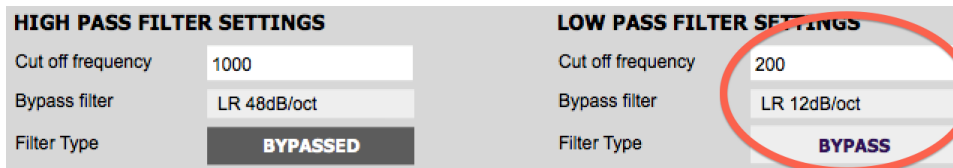

On the **Routing** tab, set the matrix like this:

	Left FR	Right FR	Left W	Right W
Dirac 1	0dB	Off	0dB	Off
Dirac 2	Off	0dB	Off	0dB

You may need to do measurements with Room EQ Wizard (or a similar program) to fine-tune your crossover settings. After you have set up the DDRC-24 plugin, save your configuration to a file. Then quit the DDRC-24 plugin, start Dirac Live Calibration Tool, and run a Dirac Live calibration as described in sections 5 and 6.

4.3.4 Stereo room correction and two-way active speaker

The miniDSP DDRC-24 can implement a two-way active speaker as well as provide room correction. This diagram illustrates the connections:

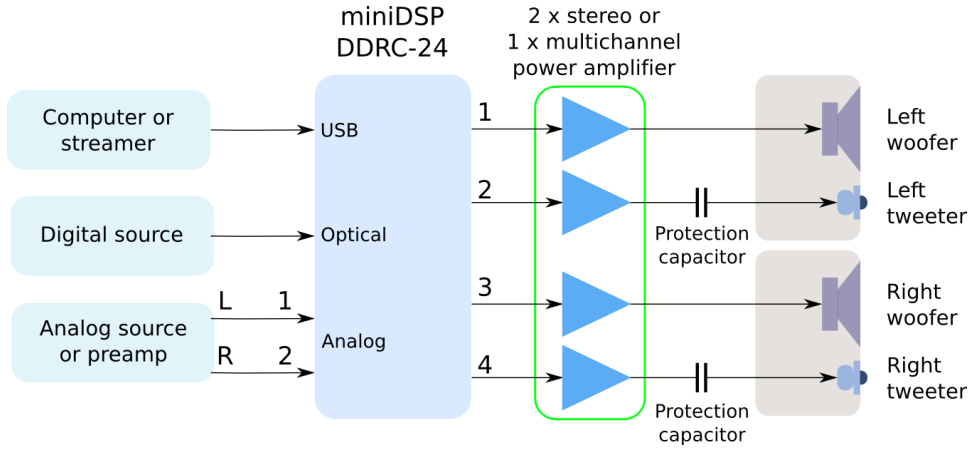

On the **Outputs** tab, rename the output channels (left to right) to “Left W”, “Left Tw”, “Right W” and “Right Tw”.

On the **Routing** tab, set the matrix like this:

	Left W	Left Tw	Right W	Right Tw
Dirac 1	0dB	0dB	Off	Off
Dirac 2	Off	Off	0dB	0dB

On the **Outputs** tab again:

- Use Room EQ Wizard or a similar program to measure each individual driver (woofer and tweeter) and equalize their response flat with the PEQ blocks. This procedure is the same as for the 2x4 HD, as described in our app notes [at this link](#).
- Set up your high pass and low pass crossover filters. This procedure is the same as for the 2x4 HD, as described in our app notes [at this link](#). This is a typical low pass setting for the woofers:

HIGH PASS FILTER SETTINGS		LOW PASS FILTER SETTINGS	
Cut off frequency	80	Cut off frequency	3000
Bypass filter	BW 24dB/oct	Bypass filter	LR 24dB/oct
Filter Type	BYPASSED	Filter Type	BYPASS

This is a typical high pass setting for the tweeters:

HIGH PASS FILTER SETTINGS		LOW PASS FILTER SETTINGS	
Cut off frequency	3000	Cut off frequency	5000
Bypass filter	LR 24dB/oct	Bypass filter	LR 48dB/oct
Filter Type	BYPASS	Filter Type	BYPASSED

After you have set up the DDRC-24 plugin, save your configuration to a file. Then quit the DDRC-24 plugin, start Dirac Live Calibration Tool, and run a Dirac Live calibration as described in sections 5 and 6.

5 ACOUSTIC MEASUREMENT FOR DIRAC LIVE

The **Dirac Live Calibration Tool Stereo for miniDSP** uses a set of measurements made in your listening room to calculate correction filters for the left and right channels. The measurements are made using the DDRC-24 processor and a miniDSP UMIK-1 measurement microphone.

5.1 LOUSPEAKER AND MICROPHONE POSITIONING

Prior to performing acoustic measurements, optimize your loudspeaker and listening positions. Start with the recommendations of the manufacturer of your loudspeakers. Loudspeakers designed for home hifi use typically perform best away from the walls, whereas speakers designed for studio use may be designed for use closer to walls or other surfaces. With Dirac Live®, you have more freedom with loudspeaker placement but the best result will still be achieved if optimal loudspeaker placement is used together with Dirac Live®.

You should also experiment with toe-in – many loudspeakers benefit from pointing directly at the listening position or even slightly in front. The listening position should be away from the rear wall, as placing the listening chair or sofa right against the wall will result in increased early reflections and changes in timbre.

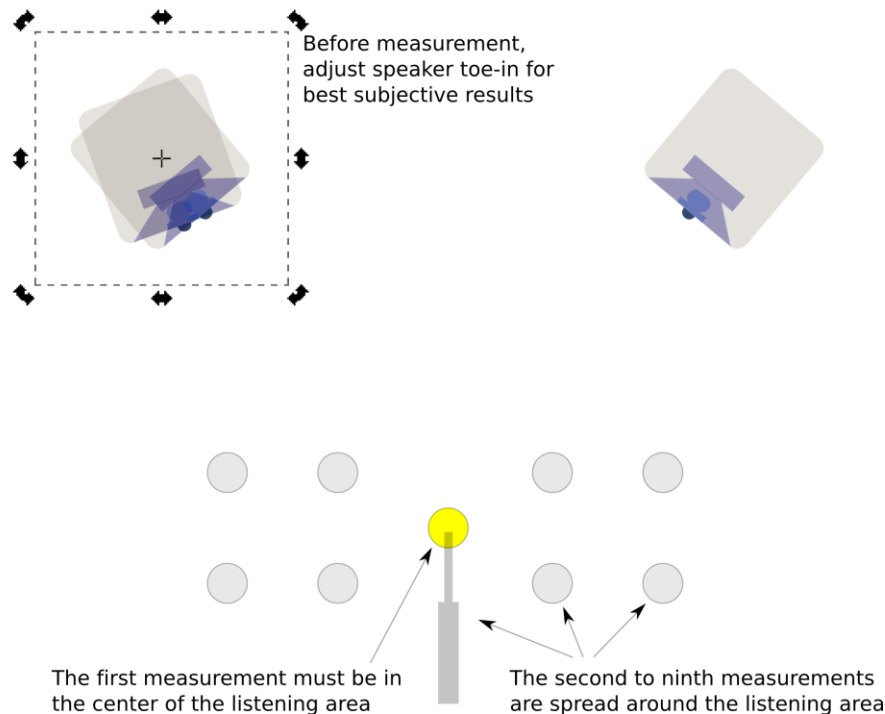

A total of nine measurements must be taken, with the microphone located in different positions in the room and pointed between the two speakers. The first measurement must be taken at the central location of the listening area, as this location sets the levels and delays of each speaker. While this location will usually be an equal distance from both speakers, Dirac Live® will adjust in cases where it is not. Eight more measurements are then taken at locations spread around the listening area and at different heights from the floor.

5.2 CONNECTIONS FOR ACOUSTIC MEASUREMENT

The figure below shows a typical connection diagram for performing acoustic measurement. No changes to existing audio connections are needed. Simply:

1. Connect the supplied USB (type A to mini type B) cable from the processor to a USB port on the computer.
2. Connect the supplied USB (type A to mini type B) cable from the UMIK-1 to a USB port on the computer.

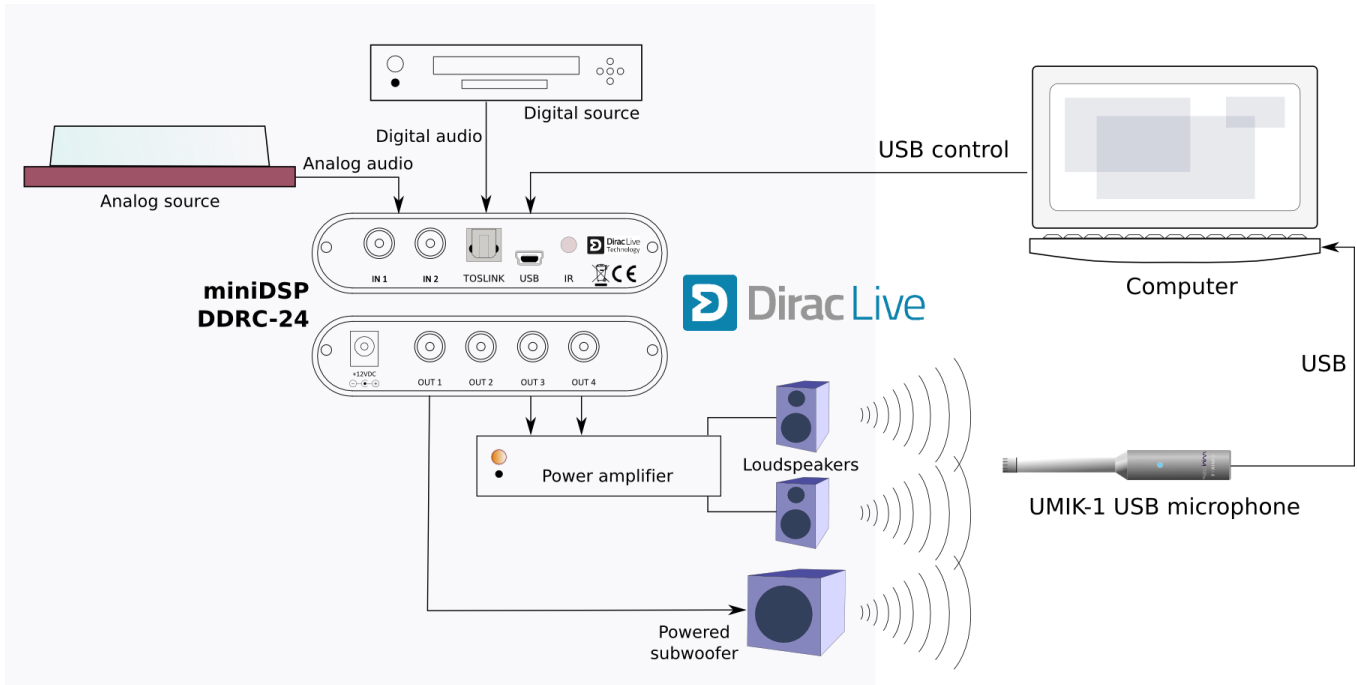

Place the UMIK-1 microphone into the microphone stand and point it between the speakers. Position the computer and cabling so that there is enough freedom of movement to move the microphone into the needed locations.



5.3 CHECK YOUR CONFIGURATION/PRESET

When you run a measurement for Dirac Live calibration, the Dirac Live test signal passes through the Routing matrix and the output channel processing. Therefore, it is important that you have the correct configuration before running the calibration measurement.

So for example, suppose you have set up your routing and output channels for a subwoofer crossover in configuration 2. Before quitting the DDRC-24 plugin, select configuration 2. (Or, if you have set up an infrared remote, you can do it at any time with the remote.)

5.4 CONFIGURING FOR MEASUREMENT

Start **Dirac Live Calibration Tool Stereo for miniDSP**.



Be sure to quit the **DDRC-88 Utility** program before starting **Dirac Live Calibration Tool for miniDSP**. Running the two programs at the same time will result in communication conflicts and odd behavior.



The main areas of the interface are:

Logo and status progress bar

This area shows a progress bar with current status when the program is performing calculations.

Selection tabs

Each tab selects a different step of the calibration process. These are generally worked through in order, from top to bottom. This section covers the first four tabs; the final two are covered in [Dirac Live Filter Design and Download](#).

Load and save a project

Projects can be saved to a file and reloaded at a later time. See [Saving and loading projects](#).

Back to previous / proceed to next

Use these two buttons to advance to the next tab when each is complete, or to go back to the previous tab to make alterations. The tabs at the left can also be clicked on directly.

Help open/close

Click on the small Help divider at the right of the window to open a pane with help on the currently selected tab. Click on the divider again to close the help pane.

5.4.1 Sound System tab

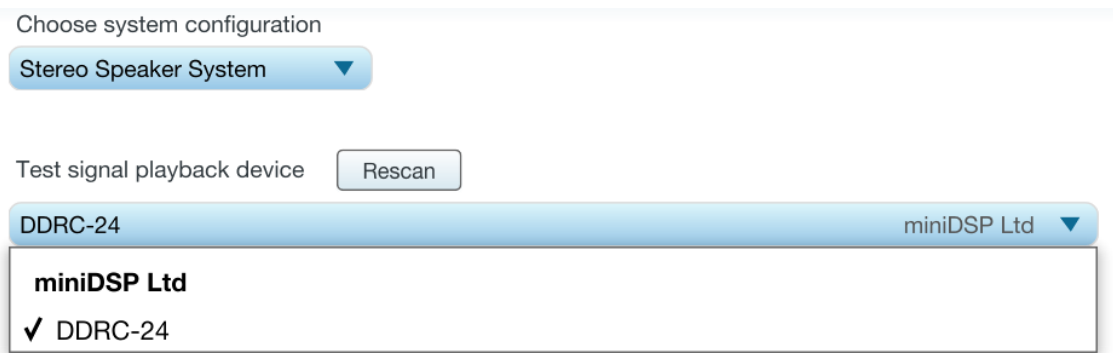

The **Sound System** tab is preset for you, provided that you have your DDRC-24 and UMIK-1 connected to the computer via USB.

Choose system configuration

Preset to **Stereo Speaker System**. This is the only configuration supported by the DDRC-24.

Test signal playback device

Preset to **DDRC-24**. (If this is not present, check that your DDRC-24 is connected via USB and powered on, then click the **Rescan** button.)

Once you have verified that this tab is correct, click the **Proceed** button.

5.4.2 Mic Config tab

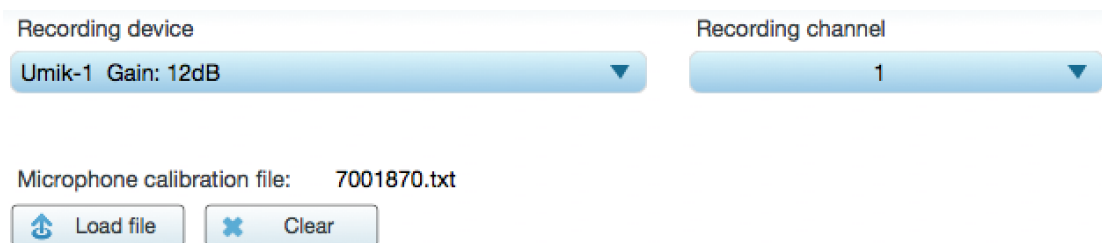

On the **Mic Config** tab, set the following parameters.

Recording device

Preset to the **UMIK-1**. (If this is not present, check that the UMIK-1 is connected securely to the computer via its USB cable, then go back to the **Sound System** tab and click on **Rescan**. Then select the “Microphone” item underneath “UMIK-1”, as shown at right.)

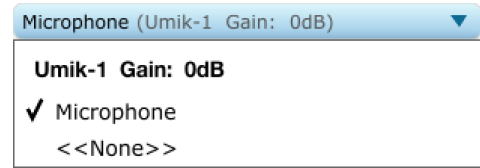

Recording channel

Select **1** from the drop-down menu.

Microphone calibration file

Each UMIK-1 measurement microphone is individually calibrated to ensure accuracy. To download the unique calibration file for your microphone, go to the [UMIK-1 page](#) and enter your microphone's serial number. It is in the form xxx-yyyy and labelled on the microphone.

Then click on the **Load File** button and select the regular or “on axis” calibration file. Usually, it will be saved to the computer with a name that is the same as the serial number e.g. “7001870.txt”. (Do not use the calibration file with “_90deg” in the name e.g. “7001870_90deg.txt” unless you are pointing the microphone at the ceiling.)

Once you have verified that this tab is correct, click the **Proceed** button.

5.4.3 Output & Levels tab

On the **Output & Levels** tab, set **Output volume** quite low.

Click on the **Test** button for the left channel and gradually increase the output volume until it is at a moderate level, such that your voice would have to be raised to converse with someone sitting next to you.

Now increase the **Input gain** slider until the blue bar on the level meter reaches up into the green section, as shown below.

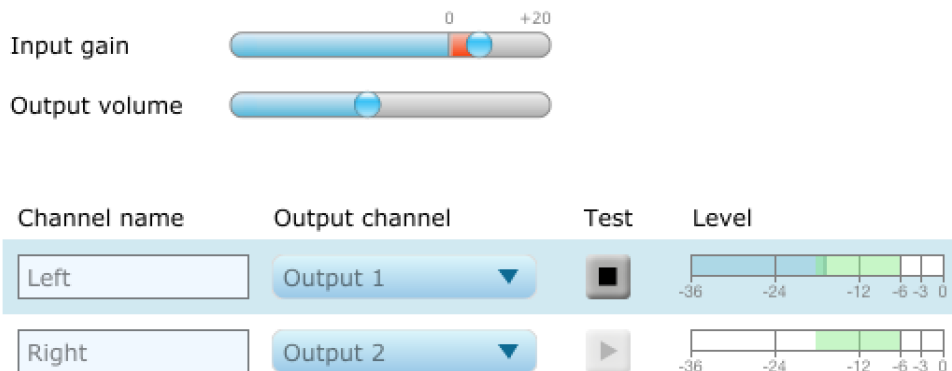

Click again on the **Test** button for the left channel to stop the test signal. Then click on the **Test** button for the right channel. If necessary, adjust **Input gain** or **Output volume** so that both channels are in the green.

When done, click the **Proceed** button.

5.5 RUNNING THE MEASUREMENTS

Measurements are performed on the **Measurements** tab.

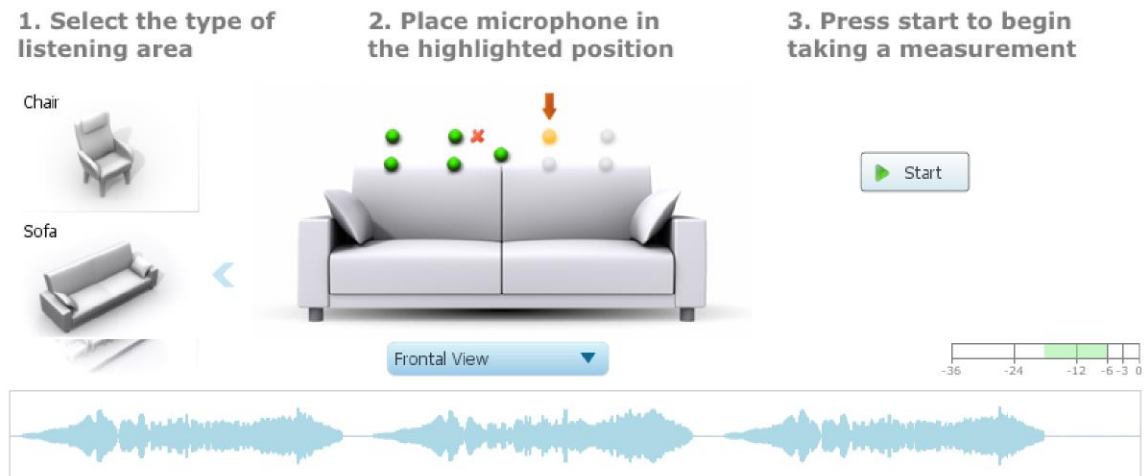

Measurements should be performed under good conditions. While the measurement technique used by Dirac Live is quite robust, low-frequency noise (traffic, machinery, aircraft, storms) in particular can adversely affect measurement accuracy. A high level of ambient noise can degrade signal to noise ratio and prevent the algorithm from analyzing the test sweep signal properly. Minimize the effect of any external noise, ensure that measurement signal levels are adequate, and/or choose a suitable time for performing measurements.

5.5.1 Listening environment

The **Dirac Live Calibration Tool Stereo for miniDSP** presents two different listening environments as a visual guide to positioning the microphone for each measurement: **Chair**, for a single listening seat, and **Sofa**, for multiple listening seats. Select a listening environment by clicking on the chosen icon.

The pictorial representation of the selected listening environment has a set of dots marking the microphone locations. Completed measurements are green, while the next measurement to be done is yellow and has a red arrow marker pointing to it. A drop-down menu underneath selects three different views, which should be used to help you place the microphone in the correct location.

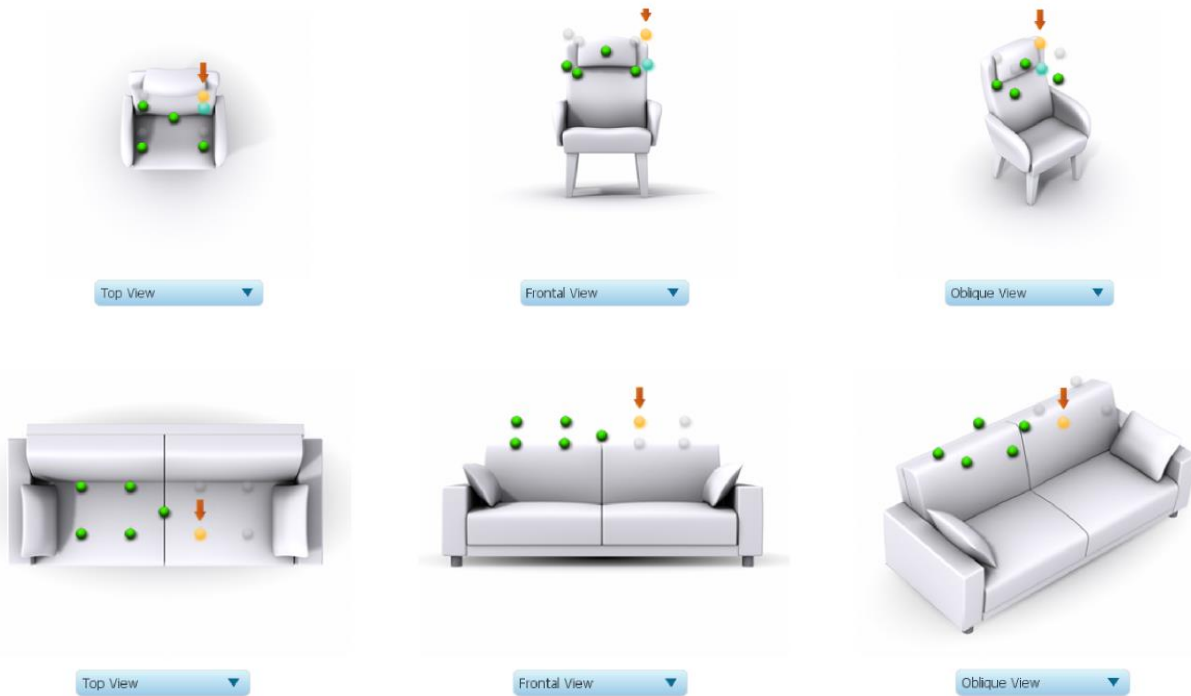

While the visual guide indicates a suitable set of microphone locations, these locations can be varied to suit individual circumstances. It is, however, imperative that the first measurement is taken in the center of the listening area, as this measurement is used to set the levels and delays of each channel. The subsequent eight measurements should be well spread out over the entire listening area so that Dirac Live can acquire a good set of measurements that capture the acoustic behavior of the room. Placing all microphone locations too close to each other may result in “over-correction” that will sound dry and dull.

For example, if using the **Chair** listening area, spread the microphone positions over a circle with a diameter of at least a meter (three feet) and vary the microphone height from the central position by at least 30 cm (one foot) up and down. If using the Sofa listening environment, spread the measurement locations over the full listening area and vary the height up and down by at least 30 cm (one foot).

A different set of locations other than those indicated by the visual guide and the above guidelines can be used if necessary. The important thing is to ensure that the measurement locations are spread out over the whole listening area and that the microphone is moved a sufficient distance vertically as well as horizontally.

In some cases, such as when the listening area is very close to the loudspeakers or the loudspeakers have a very narrow dispersion pattern, the size and in particular the height of the measurement area can be reduced, to avoid discrepancies caused by varying output response from the speakers themselves.

5.5.2 Executing measurements

With the microphone in place at the central location and pointed between the two speakers, click on the **Start** button. The DDRC-24 will generate a test signal, audible as a frequency sweep through the left speaker, then the right, and then the left again. While the measurement proceeds, the time-domain graph of the captured audio signal is displayed at the bottom of the measurement tab. (This graph is related to the magnitude response but is not the same display. Its purpose is to verify that the recorded signal level is in a suitable range.)

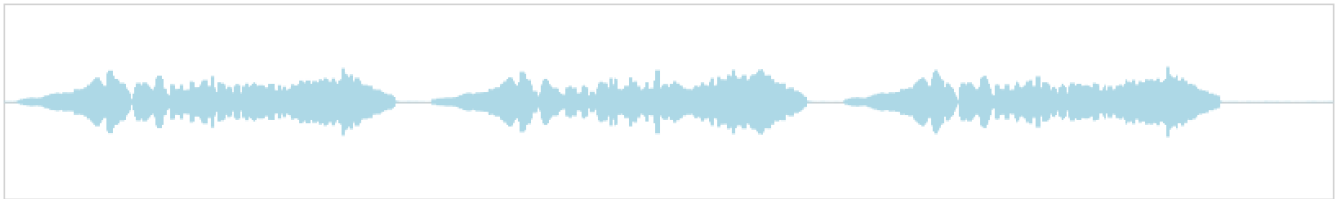

At the completion of the measurement, the status bar will update with a progress indicator as the program performs calculations on the measurement. If the measurement was successfully captured, the red arrow marker will advance to the next location to be measured. If the program indicates that the measurement was not successful, you will need to take corrective action. The most common error is related to signal level:

- The measurement signal is too low to ensure a clean capture.
- The measurement signal is too high and the audio signal has exceeded the maximum level (clipping). This is shown in red on the signal graph.

In either of the above cases, go back to the **Output & Levels** tab and adjust **Output volume** or **Input gain**. Then re-run the measurement. (You do not need to redo the measurements you have already successfully completed.)

5.5.3 Viewing and redoing measurements

Click on the green dot for any completed measurement to display its measured time-domain response graph.

After clicking on a green dot, a small red “X” will appear next it. Click on the “X” to delete the measurement. The status bar will indicate that the program is recalculating parameters.

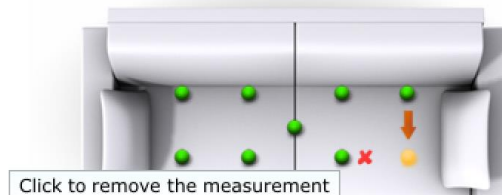

To redo a measurement, delete it, move the microphone to the appropriate location, and click on **Start**. Note: if more than one measurement is deleted, the marker will move to the lowest-numbered one.

5.5.4 Completing the measurements

After each successful measurement, the location marker (red arrow) will advance to the next location. Move the microphone to that location, using the three views (top, front, oblique) as a guide to positioning it in the correct location. Then click on **Start** again. Repeat this process until all nine locations have been successfully measured.

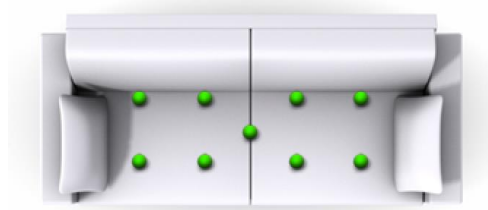

Note that it is good practice to save the project periodically while performing measurements (see [Saving and loading projects](#)). Once all nine measurements have been completed, you can advance to the **Filter Design** tab by clicking on the **Proceed** button or directly on the **Filter Design** tab at the left.



It is important that all nine measurements are completed in order to ensure best results from the optimization algorithm. Being patient and thorough will pay audible dividends!

5.6 SAVING AND LOADING PROJECTS

Each set of measurements and the associated configuration settings are a single *project*. The project should be saved at regular intervals. This is done by clicking on the **Save** button. The default location for project files is **My Documents\MiniDSP\Projects** (Windows) or **Documents/MiniDSP/Projects** (Mac).

A project can be reloaded at any time by clicking on the **Load** button. This enables you to generate new correction filters for different target curves at a later date, or to redo any of the measurements. (Note: if you wish to change from the **Chair** to the **Sofa** listening environment, or vice versa, you will need to start a new project.)

6 DIRAC LIVE FILTER DESIGN AND DOWNLOAD

Once the full set of measurements has successfully been taken, **Dirac Live Calibration Tool Stereo for miniDSP** has the acoustical information it needs about your loudspeakers and listening room to create the correction filters.

6.1 WORKING WITH GRAPHS

The **Filter Design** tab shows a number of plots that can individually be turned on and off with the checkboxes near the top.

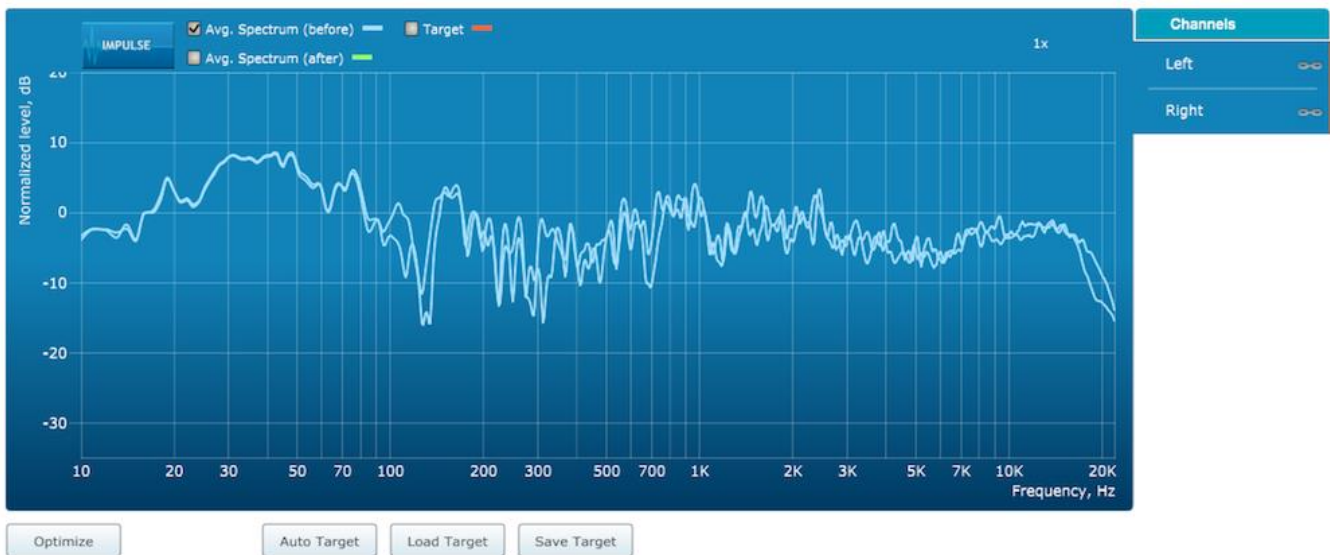

Avg. spectrum (before)

The average of the measured magnitude responses. These plots are shown in light blue.

Avg. spectrum (after)

The predicted average magnitude response after correction. These plots are shown in green, and can only be viewed after filters have been generated with the **Optimize** button.

Target

The target curve – that is, the desired in-room magnitude response. This curve is user-adjustable so you can fine-tune it to best suit your speakers, room, and preferences. See [Designing your target curve](#).

To display the impulse response instead of the magnitude response, click on the **Impulse** button at the top left of the display. There are two graphs that can be turned on and off with the checkboxes at the top: the measured impulse response (shown in light blue), and the predicted impulse response after correction (shown in light green).

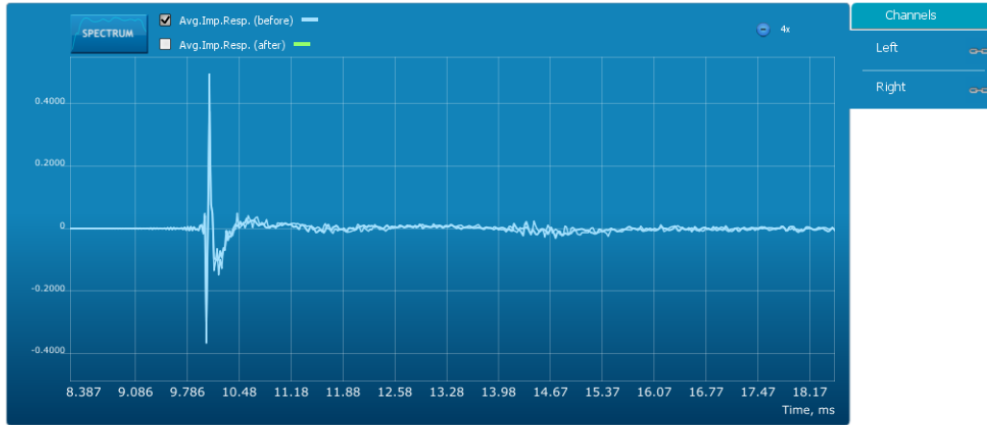

To return to the magnitude response, click on the **Spectrum** button.

The magnitude and impulse response graphs can be viewed at a larger scale. To zoom in and out on the response graphs:

- Drag-select a region of the graph to zoom in on it. (Click the left button, move the mouse while holding the button, release the button.) You can then drag-select a region again to zoom in further.
- Double-click on the graph to zoom back out to the previous zoom level, or click on the small “-” sign next to the zoom indicator at the top right of the display.

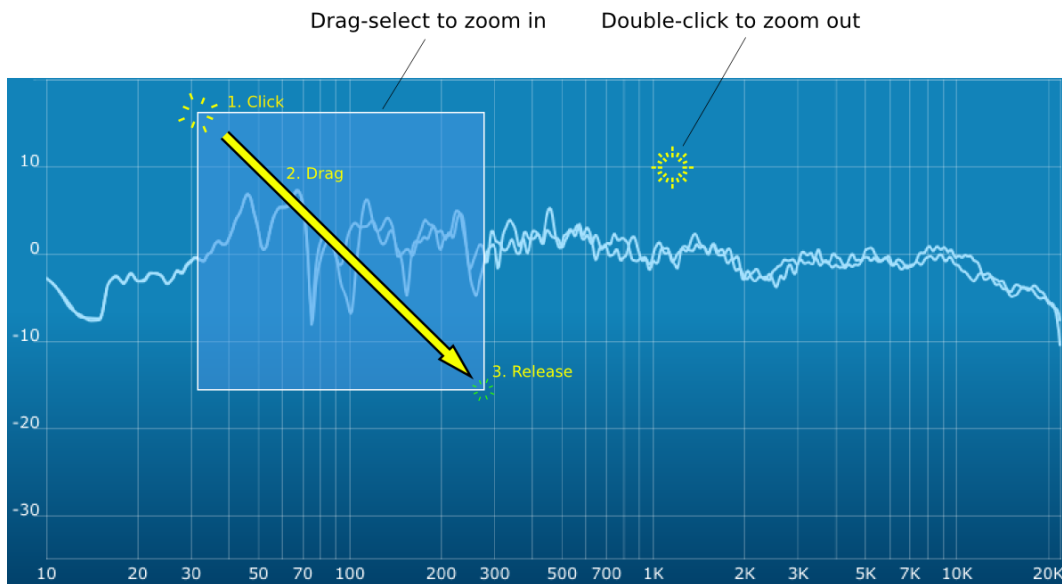
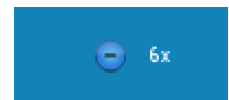

By default, graphs of both left and right channels are shown together. The left and right channels can be unlinked by clicking on the small “chain” icon next to the channel name, at the right of the graphs. Then the graphs of each channel can be viewed separately, by click on the “Left” or “Right” tab. To relink the two channels, drag the “disconnected” channel tab over the top of the selected channel.

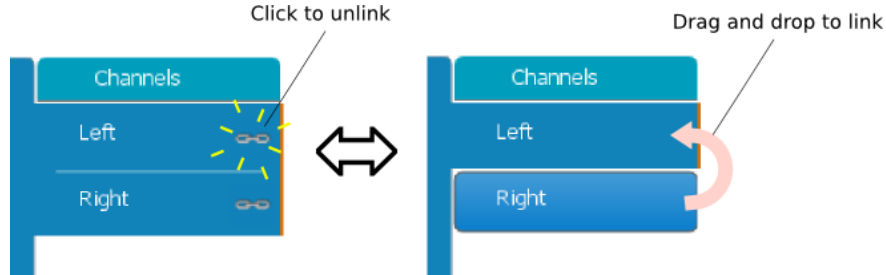

6.2 DESIGNING YOUR TARGET CURVE

The *target curve* is the desired in-room frequency response with the miniDSP DDRC-24 performing digital room correction.

6.2.1 The Auto Target

When first viewing the **Filter Design** tab, an estimated target curve suitable for your speakers is shown as the red curve. This calculated target curve can be restored at any time by clicking on the **Auto Target** button.



Note: restoring the auto target will erase the current target curve. If you wish to keep it, you can save it to a file – see [Saving and loading target curves](#).

6.2.2 Editing the target curve

You can edit the target curve to set any desired magnitude response (see [Guidelines for target curve design](#)). This is done with the use of *anchor points*, shown as orange dots on the curve:

- Drag an anchor point to move it.
- Double-click on the target curve to add an anchor point.
- Double-click on an anchor point to delete it.

The regions to the left and right of the response graphs that are shaded in a darker color are excluded from correction. You can adjust the range of frequency correction for your system and environment. For example, low-frequency noise (traffic, machinery) may be present in some environments, so it is best to adjust the frequency range to exclude these frequencies from the correction. Or, you may be happy with the in-room response at higher frequencies, so you can set the frequency region to limit correction to the modal region (up to 300 Hz, in a typical room).

To alter the frequency region, drag the grey handles on either side of the graph. Note that you can't drag these handles over an anchor point, so you may need to move or delete an anchor point that is "in the way."

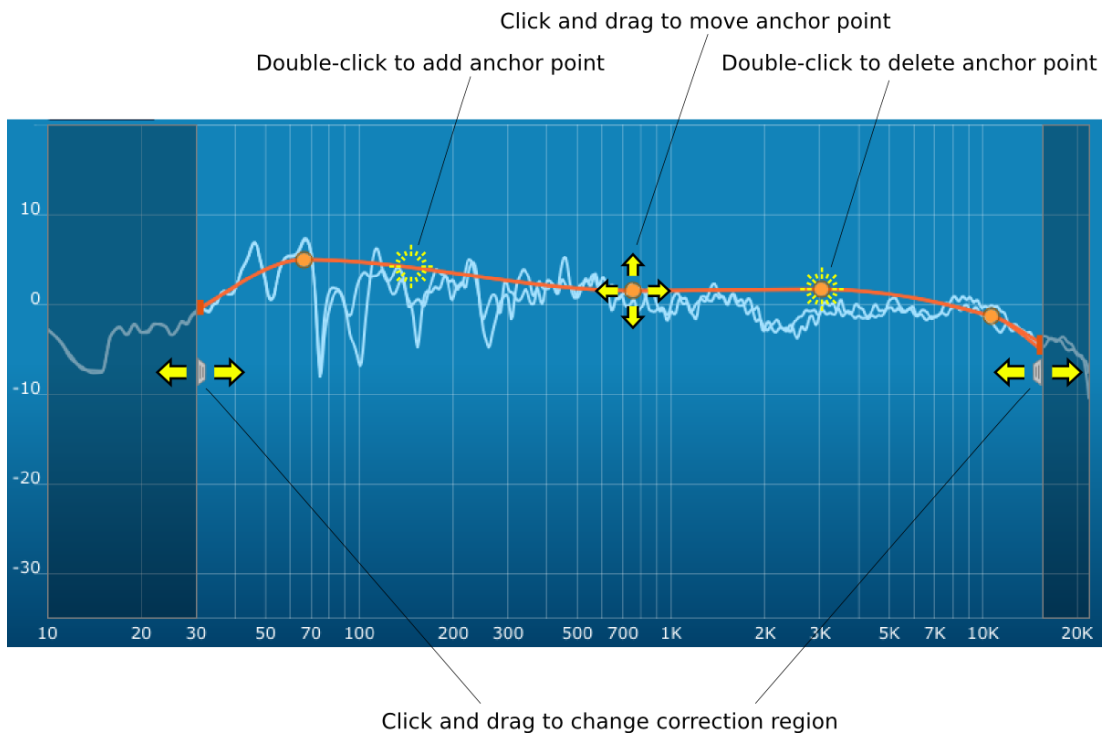

If the left and right channels are linked, the same target curve is used for both channels. To create separate target curves for the left and right channels, unlink the two channels as described in [Working with graphs](#).

6.2.3 Guidelines for target curve design

Care should be taken to create a target curve that works well with your speakers and room, as well as suiting your personal preferences. Small changes to the target curve can have significant effects on the tonal quality of the system, so it is important that you experiment with different target curves to find the optimum.

If you initially don't achieve a satisfactory result, please ensure that you have spread your measurements over a sufficiently large area and with sufficient variation in height. The following guidelines will help you understand how to adjust your target curve.

Low-frequency extension and boost

All loudspeakers have a natural low-frequency roll off. Setting the target curve to boost the region below the speaker's natural roll off frequency *may* result in overdriving the speakers, especially with smaller home loudspeakers and depending on your listening habits. A system with capable subwoofers integrated into it, however, will support much more low-frequency output.

The auto-target estimates the low-frequency roll-off and curve, and in some cases may include some amount of boost if it estimates that the speakers are capable of handling it. You should determine by *listening* whether this estimate is suitable for your speakers, and adjust the target curve accordingly.

High-frequency "tilt"

The target curve is the desired measured response of loudspeakers *in a room*, In contrast to measurements made of a loudspeaker during its design under anechoic (measured in free space) conditions. While high-quality loudspeakers are usually designed for a flat on-axis anechoic response, these same speakers when placed into a listening room will tend to have a downward-sloping or "tilting" response at high frequencies, due to the effects of limited dispersion at high frequencies and greater acoustic absorption.

A completely flat in-room response is therefore usually not desirable and will tend to sound thin or bright. Start with a target curve that follows the natural behavior of your speakers in your room, and then experiment with greater or lesser degrees of tilt in the treble region to obtain the most natural timbral balance.

Low-frequency adjustment

A completely flat response at low frequencies, with complete elimination of peaks due to room modes, may sound light in the bass. Often, a slight increase in the target curve below 100 Hz will give a more balanced sound, yet without introducing audible irregularities in bass response.

Magnitude response dips

In some cases, it may be helpful to adjust the target curve to follow dips in the magnitude response. This can occur where, for example, the listening area is very close to the speakers and the measurements exhibit a dip caused by the vertical response of the speakers themselves. In such a case, adjusting the magnitude response to follow the dip will avoid making the speakers sound worse elsewhere in the room. (You may also wish to try a different set of measurement locations.)

Unlinking channels

In almost all cases, the left and right channels should remain linked for target curve adjustment, to ensure that both speakers produce the same response across the listening area. In certain unusual circumstances,

such as where the magnitude response dip discussed in the previous point shows up in only one speaker, you can try unlinking the left and right channels and making separate adjustments.

6.2.4 Saving and loading target curves

To allow you to experiment with different target curves, you can save a target curve to a file and reload it at a later time. To save a target curve, click on the **Save Target** button. If the left and right channels are linked, then the shared target curve will be saved to the file. If the channels are not linked, then the currently visible target is saved to the file.

To load a target curve, click on **Load Target**. Note that loading a target will erase the current target, so be sure to save it first if needed. If the channels are linked, then the target curve will be loaded to both channels. If the channels are not linked, then the target will be loaded to the currently visible channel.

6.3 GENERATING CORRECTION FILTERS

Once you have a target curve set to your satisfaction, click on the **Optimize** button. The **Dirac Live Calibration Tool Stereo for miniDSP** may at this time contact the Dirac license server to verify its license, so you will need to be connected to the Internet. If a firewall is in place, it must allow HTTP (normal web traffic) to pass.

The status bar will update with progress of the algorithm. Execution may take some time, depending on the speed of your computer. When the algorithm completes, the predicted average magnitude response will be shown in green. (The predicted impulse response can be viewed by clicking on the **Impulse** button.)

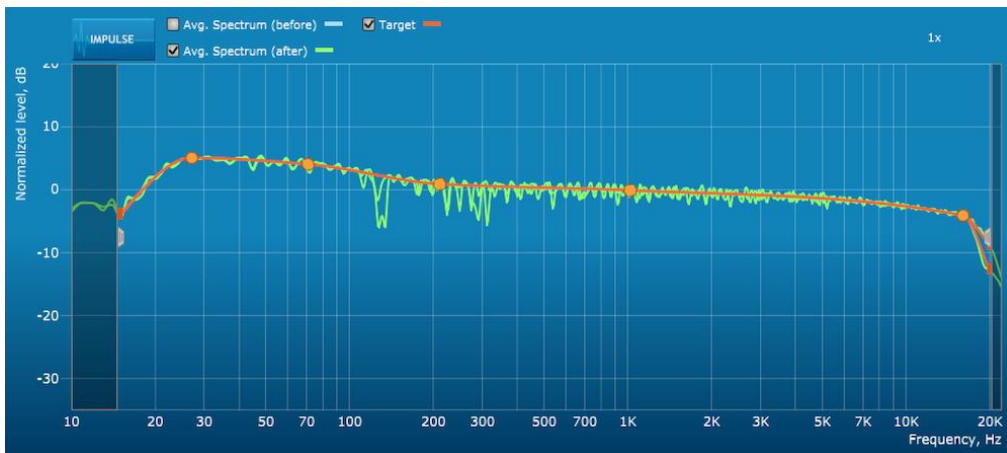

To download the generated filters into the DDRC-24, click the **Proceed** button or on the **Export** tab on the left.

6.4 LOADING FILTER SETS

The **Export** tab initially shows four empty “slots” for filter sets (a filter set is one filter for the left channel and one filter for the right channel). Filter sets are managed with a “drag and drop” metaphor:

- To load the most recently generated filter set into the processor, drag the box at the top left (labeled “More Bass” in the example) and drop it onto an empty slot (*).
- To remove a filter set, click on its name (oriented vertically), drag it from the slot and drop it on the trashcan icon at the top right.
- To load a filter set into a slot that already has filters loaded, first delete the loaded filter set by dragging it onto the trashcan icon. Then drag and drop the current filter set onto the now-empty slot.

The name displayed on the filter slot after dragging and dropping is the name of the project. This example screenshot shows two slots loaded:

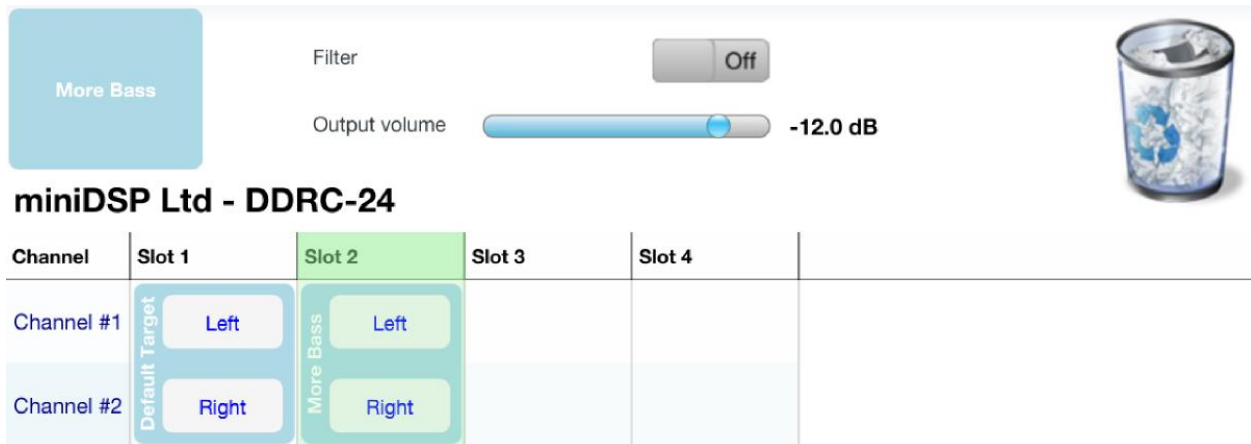

The two additional controls on this tab are:

Filter

Turn this on to enable the Dirac Live® correction filters. This function can be programmed into a remote control.



Output volume

Adjust the slider to adjust the output volume of the processor. Once the computer is disconnected, output volume can also be adjusted with a remote control.

(*) You will most likely load the filters into the same slot as the preset selected when running the measurements for Dirac Live calibration.

7 INFRARED REMOTE CONTROL

Once configuration is complete, the computer is not required and can be disconnected. An infrared remote can be used to control volume, mute, preset selection, input selection, and to turn Dirac Live processing on and off.

The DDRC-24 can “learn” the control codes of your current remote if it supports one of the following remote control codes:

- Apple
- NEC
- Sony
- Philips RC6

To initiate the learning process, drop down the IR Remote menu and select **IR learning**. Click on the **Learn** button for an operation, and then press the desired button on the remote control. If the code is accepted, the status will change to show a tick.

This screenshot shows the IR learning dialog:

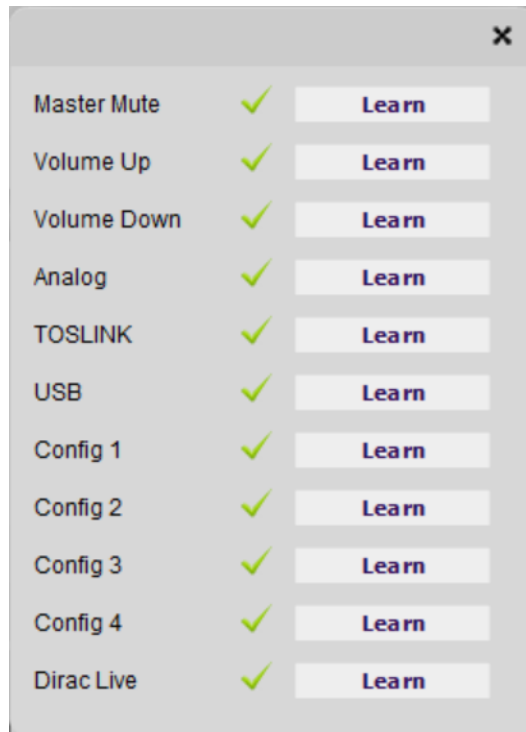

To "unlearn" a command, press the **Learn** button and wait for the plugin to time out.

8 USB AUDIO

The miniDSP DDRC-24 accepts stereo PCM audio at sample rates of 44.1, 48, 88.2, 96, 176.4, and 192 kHz on its USB audio input. The same USB connector is used both for streaming audio and configuration.

8.1 MAC OS X

Open the program **Audio MIDI Setup** (in **Applications->Utilities**). Clicking on “DDRC-24” in the list on the left hand side will show the input and output channels and allow sample rate and word length to be set.

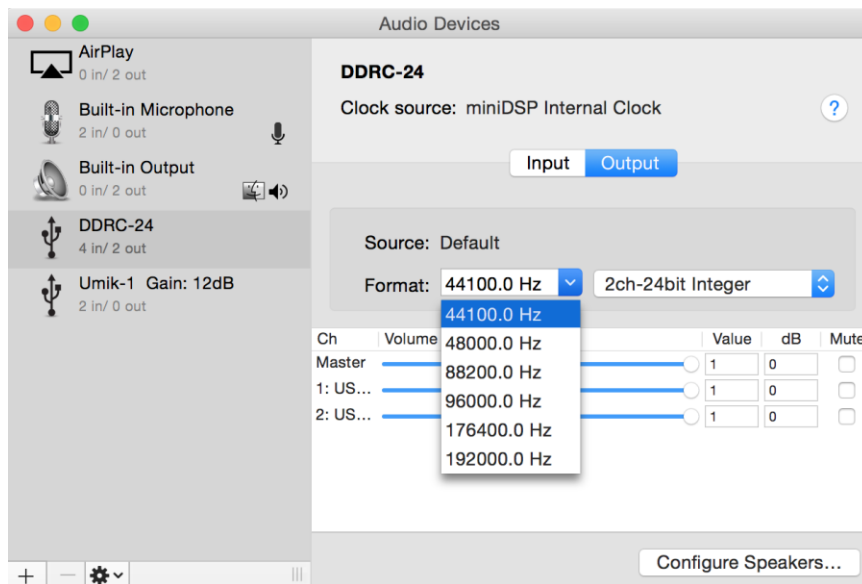

To set the DDRC-24 as the default audio output device, right-click and select “Use this device for sound output”. Individual audio playback programs may allow the DDRC-24 to be selected independently of the system default.

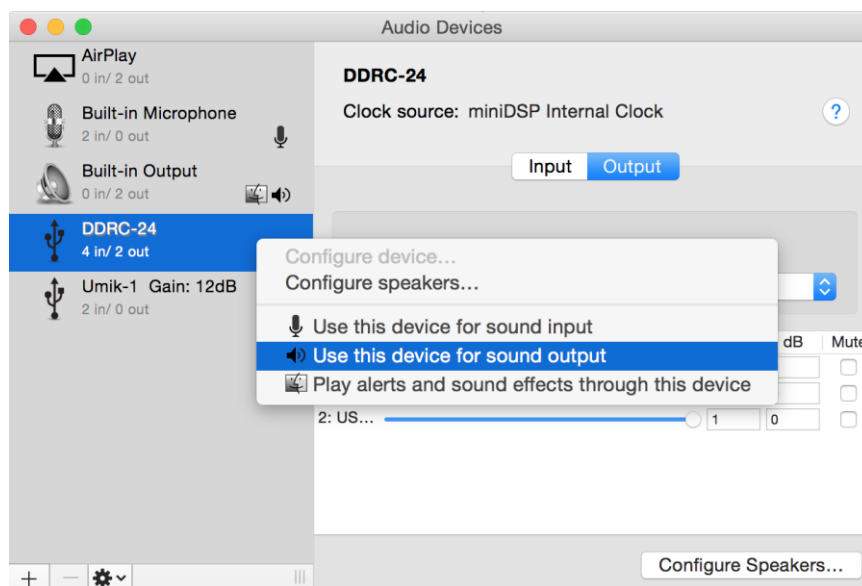

8.2 WINDOWS

Open the UAC Control Panel from the Windows Start menu. This control panel allows you to set a number of options, such as word length (Format tab) and buffer size (Buffer tab). We recommend that you leave these settings at their defaults.

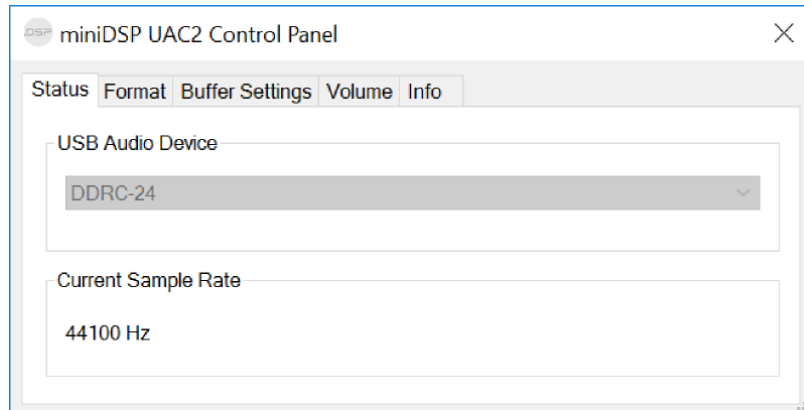

If you are having an issue with inadequate output volume over USB playback, check the Volume tab.

To set the DDRC-24 as the default output device, open the Windows Control Panel and navigate to the Audio Devices section. On the Output tab, select DDRC 2x4n and click on the “Set Default” button. Individual audio playback programs may allow the DDRC-24 to be selected independently of the system default.

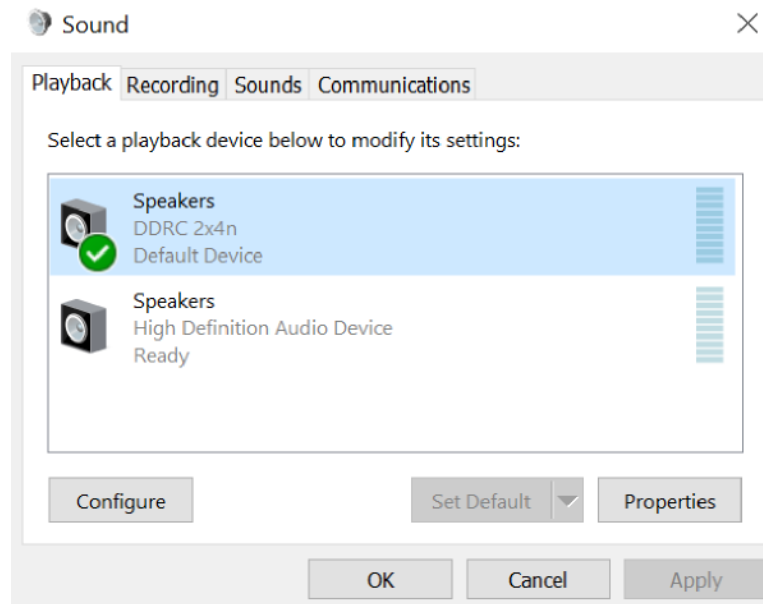

9 PLUGIN REFERENCE

This section provides full details on each of the plugin processing blocks.

9.1 INPUT CHANNEL STATUS

Each input channel strip displays useful information about the levels and Dirac settings on that channel. The plugin must be online to display information here.

Channel label

The name of the channel. These are set to “Dirac 1” and Dirac 2” and cannot be renamed.

Level meter, Current RMS level

Displays the current signal level in real time.

Dirac Live level

Graphical and numerical display of the gain (in dB) that Dirac live has set for this channel.

Dirac Level delay

Numerical display of the delay (in milliseconds) that Dirac live has set for this channel.

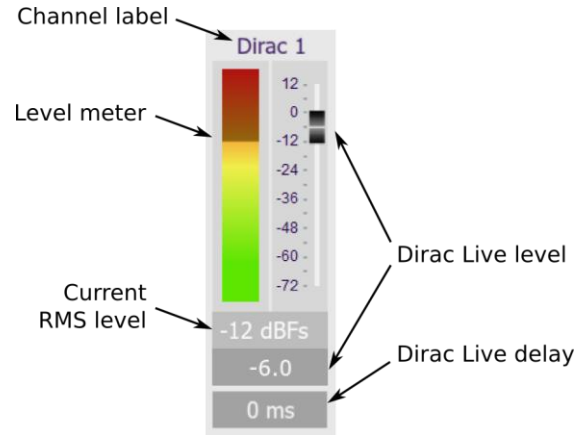

9.2 ROUTING

The **Routing** matrix mixer is used to direct input channels (along the left) to output channels (along the top). To turn on routing for a cross point, click on that cross point. At each cross-point, the gain of the signal being mixed can be adjusted to a value between -72 and +12 dB. To adjust the gain, right-click on the cross point and a gain control will appear. Adjust the gain with the slider, or by typing in the value directly, then click **close**.

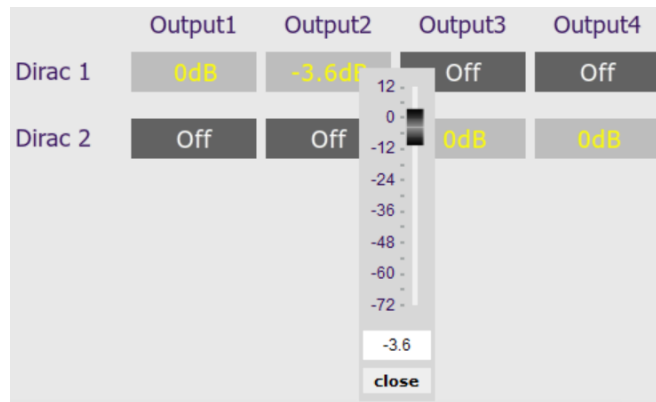

9.3 OUTPUT CHANNELS

Each output channel has a complete "strip" of controls.

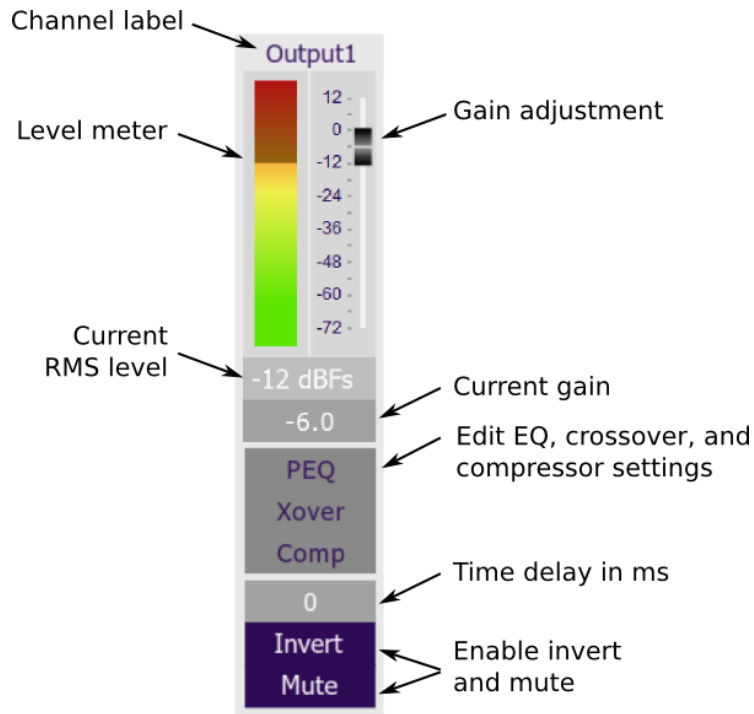

9.3.1 Channel label

Each output channel has a customizable label, which is shown at the top of the channel strip. This label also appears on the **Routing** matrix. To change the label, click on it, type a new label (up to eight characters), and press the Return key.

9.3.2 Level metering and gain adjustment

Level meter, current RMS level

Display the current signal level both graphically and numerically in real time. (The plugin must be online to display signal levels.)

Gain adjustment, current gain

The gain of each channel can be adjusted by moving the Gain Adjustment slider, or by typing the desired gain into the Current Gain text box. The maximum gain setting is 12 dB, and the minimum gain setting is –72 dB. (0 dB, the default, is unity gain or no change in level.)

9.3.3 Parametric EQ

Parametric equalization (PEQ) is a flexible type of equalization filter. It can be used to correct for errors in loudspeaker output, to compensate for acoustic room effects, and to tailor the overall system response for best sound. Click on the PEQ button to open the parametric equalizer settings window:

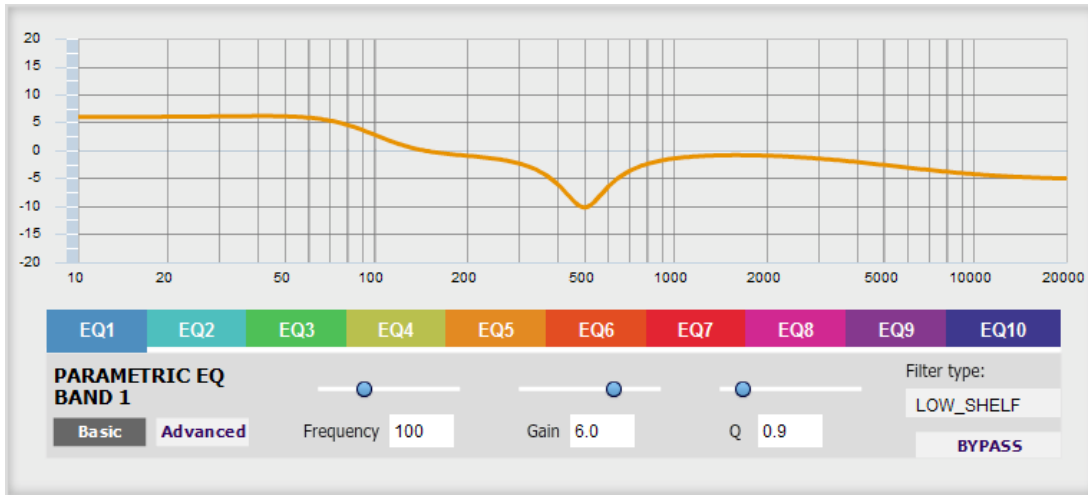

There are ten parametric EQ filters on each output channel. The window displays a frequency response graph showing the combined response of all enabled parametric filters on that channel. For example, the screenshot above shows a response curve created with a low-shelf boost filter at 100 Hz, a dip at 500 Hz, and a high-shelf cut filter at 5000 Hz.

Hovering the mouse over the curve brings up an overlay showing the frequency and the gain at that frequency.

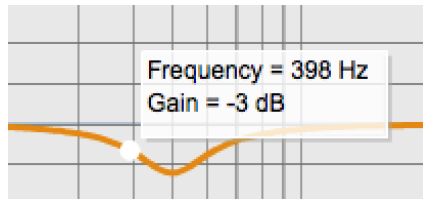

Each channel can be linked to one other channel. When a channel is linked to another, the PEQ settings of that channel are mirrored to the other. Typically, corresponding channels on the left and right are linked: for example, left and right tweeter and left and right woofer. To link a channel, select the other channel from the drop-down menu at the top left of the **PEQ** display, and click the **Link** checkbox.



EQ band selection

Click on the tabs **EQ1**, **EQ2**, etc. to display the parameters for that filter.

Basic/Advanced

By default, each filter is in basic mode, and shows the controls described below. Advanced mode enables custom biquad programming for almost infinite flexibility in filter implementation. This is described in [Custom biquad programming](#) on page 50.

Filter type

Selects the type of filter:

PEAK

Create a dip or a peak in the frequency response.

LOW_SHELF

Reduce or increase part of the frequency spectrum *below* a given frequency.

HIGH_SHELF

Reduce or increase part of the frequency spectrum *above* a given frequency.

SUB_EQ

Create a dip or a peak in the frequency response at low frequencies (10 to 50 Hz). This filter type is similar to PEAK but gives more accurate results for low frequencies. Note that activating any SUB_EQ filter reduces the number of available filters on that channel from ten to nine.

Frequency

For the PEAK and SUB_EQ filter types, this is the center frequency of the peak or dip. For the HIGH_SHELF and LOW_SHELF filter types, this is the frequency at which the gain is half of the set value.

Gain

For the PEAK and SUB_EQ filter types, this is the gain in dB at the center frequency. For the HIGH_SHELF and LOW_SHELF filter types, this is the gain in dB reached at high or low frequencies respectively. A filter has no effect if its gain is set to 0 dB. Gain can be adjusted in increments of 0.1 dB up to +/- 16 dB.

Q

Q controls the “sharpness” of the filter. For the PEAK and SUB_EQ filter types, lower Q gives a broader peak or dip, while higher Q gives a narrower peak or dip. For the HIGH_SHELF and LOW_SHELF filter types, Q controls how quickly the filter transitions from no gain to maximum gain.

Bypass

The **Bypass** button enables or disables a filter. The filter is bypassed if the button is "lit". (Note that all other filters are still operational unless individually bypassed.) A filter will also have no effect if its gain is set to 0.0.



9.3.4 Crossover

Each output channel has independent high pass and low pass filters. See the [Plugin configuration guide](#) for some example uses of crossover filters.

Click on the **Xover** button to open the crossover settings window:

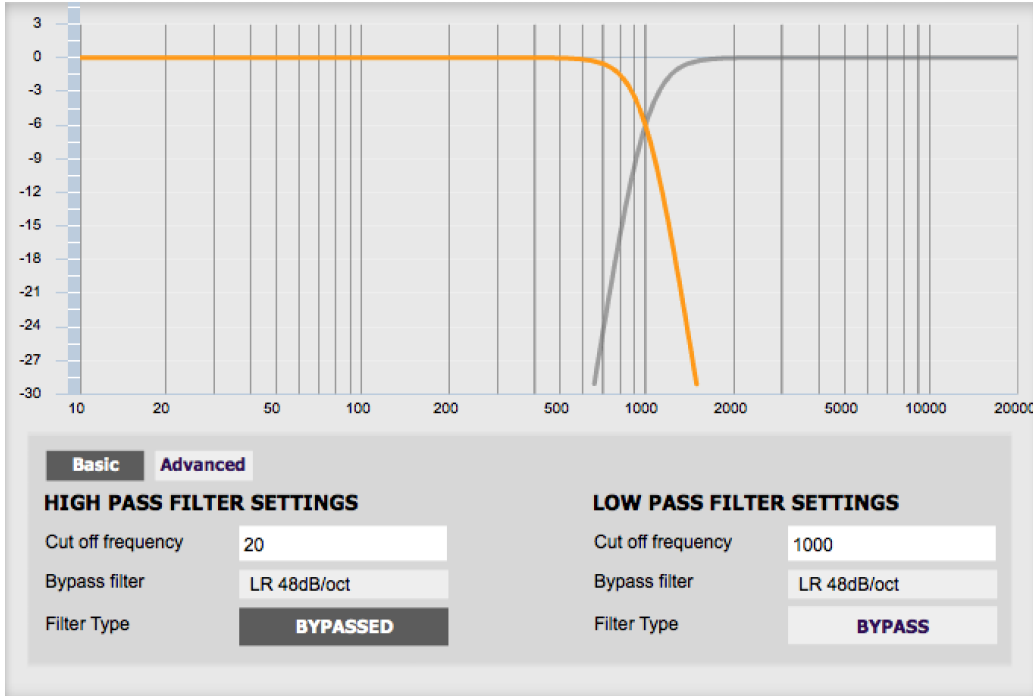

Crossovers “split” the frequency band to send to different drivers. In a two-way loudspeaker, a *low pass* filter is used to remove high frequencies from the signal sent to the woofer, and a *high pass* filter is used to remove low frequencies from the signal sent to the tweeter. When integrating a subwoofer, high pass filters are used on the speakers and a low pass filter on the subwoofer. A crossover filter can also be used to limit low frequency content delivered to a speaker or subwoofer, to help protect it from over-excursion.

Unlike conventional analog crossovers, the flexibility of DSP allows a completely arbitrary mix of different filter slopes and types. Filters can be set at any frequency, or disabled completely. This allows maximum flexibility in matching your crossover to the acoustic characteristics of the loudspeaker drivers.

The current channel is displayed in orange, with the others displayed in grey. Hovering the mouse over the curve brings up an overlay showing the frequency and the attenuation at that frequency.

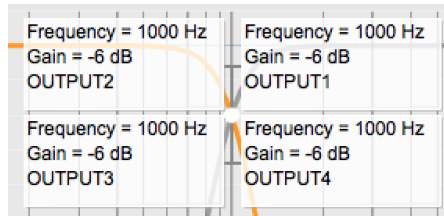

Basic/Advanced

By default, the crossover is in basic mode, and shows the controls described below. Advanced mode enables custom biquad programming for almost infinite flexibility in crossover filter implementation. This is described in [Custom biquad programming](#) on page 50.

Cutoff Frequency

Sets the nominal cutoff frequency of the crossover. In actual fact, the crossover has a more or less gradual transition from “full on” to “full off,” as determined by the filter slope.

Filter type

Selects the type and slope of the filter. The steeper the slope, the more quickly frequencies above or below the cutoff frequency are attenuated. There are three types of filter:

Butterworth (BW)

Available in 6, 12, 18, 24, 30, 36, 42, and 48 dB/octave, Butterworth crossover filters are 3 dB down at the cutoff frequency.

Linkwitz-Riley (LR)

Available in 12, 24, and 48 dB/octave, Linkwitz-Riley crossover filters are 6 dB down at the cutoff frequency.

Bessel

Available in 12 dB/octave only, a Bessel filter gives a more gradual roll-off through the crossover region.

Bypass

Clicking on the **Bypass** button disables or enables that high pass or low pass filter. The filter is bypassed when the button is "lit".



Each channel can be linked to one other channel. When a channel is linked to another, the crossover settings of that channel are mirrored to the other. Typically, the corresponding drivers on the left and right channels are linked: left and right tweeter, left and right woofer, and so on. To link a channel, select the other channel from the drop-down menu at the top left of the **Xover** display, and click the **Link** checkbox.



9.3.5 Compressor

The compressor reduces the gain of an output channel when the audio signal reaches a certain level as specified by the **Threshold** parameter. The gain of the channel will be progressively reduced as the signal increases above the threshold, according to the **Ratio** parameter. This can be used to limit the power delivered to speakers and thus reduce the risk of damage from overdriving.

This screenshot shows an example Compressor setting:

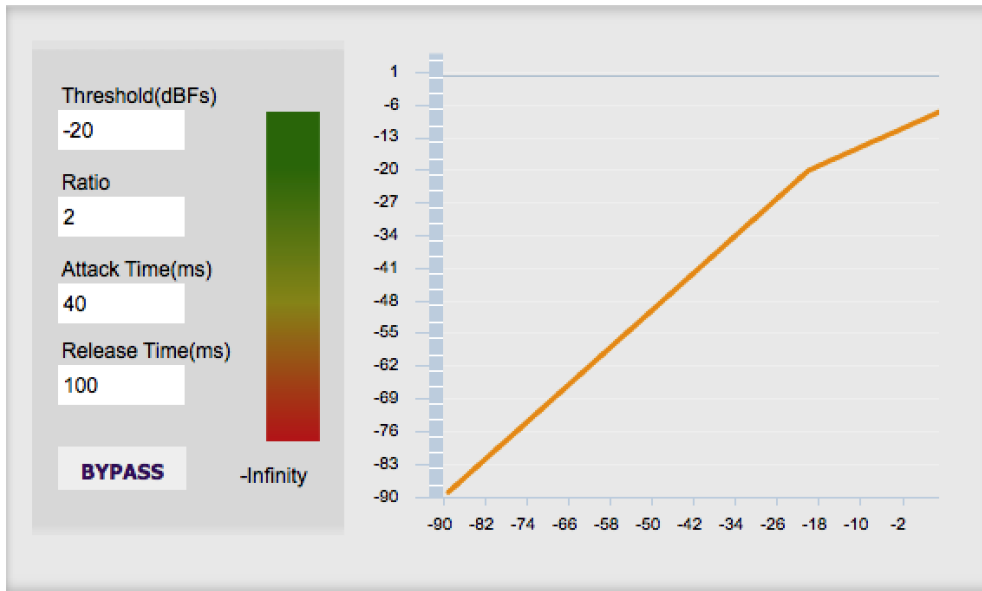

(Note that the compressor algorithm is bypassed by default, so click on the **Bypass** button to see the curve as shown here.)

In this example, the threshold is set to -20 dB, so the compressor will activate when the signal on that channel reaches -20 dB (relative to full output). The ratio is set to 2, so if the input signal level to the compressor then increases by 10 dB, the output level will increase by only 5 dB. If the input signal level to the compressor is at full scale (0 dB), then the output level will be limited to -10 dB.

Two additional parameters control the action of the compressor: the attack time and the release time. These two parameters govern how quickly the compressor activates when the signal level exceeds the threshold, and how quickly it deactivates when the signal level reduces. The optimum settings may need to be tuned by ear. For more information, see the Wikipedia article [Dynamic range compression](#).

9.3.6 Invert and mute

Each channel can be inverted in polarity, and individually muted. When either of these options is selected, the visual indicator on the button is "lit":

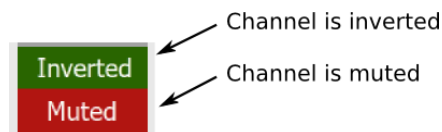

9.3.7 Time delay

A delay of up to 30 ms can be applied to each output channel. To set the delay, click in the delay entry box for a channel. The delay value can be entered numerically, and the up and down arrows can be used to change the delay in small (0.02 ms) increments. The maximum time delay of 30 ms corresponds to a distance of approximately 10.3 meters (about 35 feet).

The time delay corresponds to a distance. This distance is shown in centimeters below the entry box.

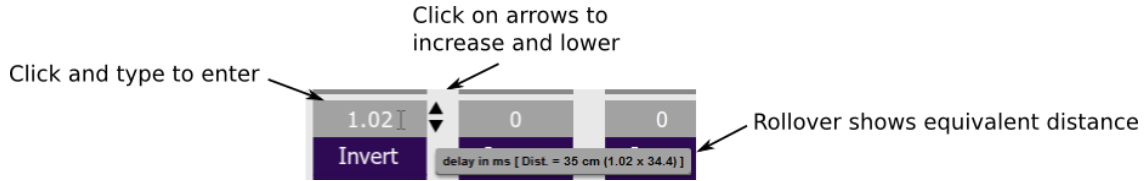

Note: The Dirac Live analysis algorithm *also* sets the time delay on the left and right channel. The time delay on the output channels should be used to time-align drivers (in the case of a two-way loudspeaker) and to optimize subwoofer integration (when the DDRC-24 is being used to drive one or more subwoofers).

9.4 CUSTOM BIQUAD PROGRAMMING

Custom biquad programming is available in the PEQ and Crossover blocks. Its purpose is to allow you to directly provide the low-level parameters aka *biquad coefficients* that control the digital filters of the processor, thus providing an almost infinite degree of flexibility.

For example, you can create hybrid crossovers with staggered cutoff frequencies, create parametric EQ filters beyond those provided in the easy-to-use “basic” interface, implement a Linkwitz transform, or mix crossover and EQ biquads in the same block.

9.4.1 What’s a “biquad”?

A biquad is the basic unit of processing that is used to create digital filters. It can be described either with an equation or with a signal flow diagram, as shown here:

$$H(z) = \frac{b_0 + b_1 z^{-1} + b_2 z^{-2}}{1 + a_1 z^{-1} + a_2 z^{-2}}$$

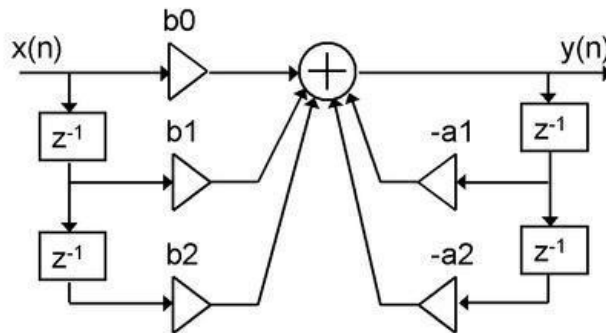

A single biquad like this can perform a great many functions, including all of the functions of a single parametric EQ filter, one 6 or 12 dB/octave high pass or low pass filter, and more. Biquads are combined in series (cascaded) to create more complex filters. The function that each biquad performs is determined by just five numbers: $a1$, $a2$, $a0$, $b1$, and $b2$. These numbers are called the *coefficients*.

9.4.2 Using custom biquad programming

Each crossover block and PEQ filter has a selector that switches it to advanced mode:



In advanced mode, the biquad coefficients can be pasted directly into the user interface. These coefficients must be calculated using a design program – see [Biquad design software](#) for suggestions.

Parametric EQ advanced mode

In the parametric EQ blocks, advanced mode allows each individual filter to be specified by its biquad coefficients. After pasting in the coefficients, click on the **Process** button.

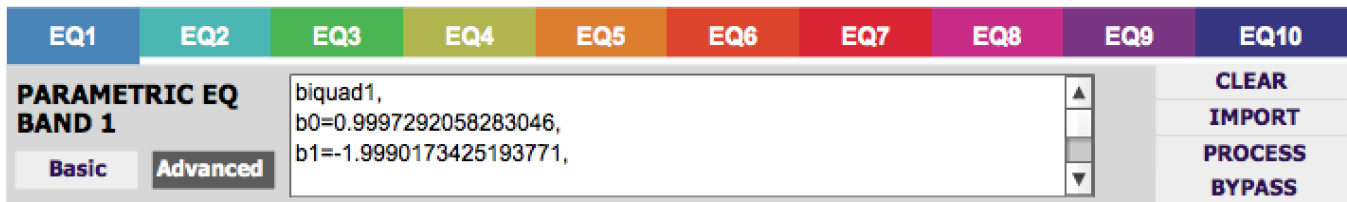

Parametric EQ file import (REW integration)

Multiple biquads in the parametric EQ block can be set at once by importing a coefficient file. This file can be generated by Room EQ Wizard (REW) or by other programs. The design program must be set for a **48 kHz** sample rate. The number of filters is limited to a maximum of ten.

This example illustrates the correct file format:

```

biquad1,
b0=0.998191200483864,
b1=-1.9950521500467384,
b2=0.996920046761057,
a1=1.9950521500467384,
a2=-0.9951112472449212,
biquad2,
b0=0.999640139948623,
b1=-1.9981670485581222,
...
biquad3,
...
biquad4,
...
biquad10,
b0=1.0010192374642126,
b1=-1.9950555192569264,
b2=0.9940580112181501,
a1=1.995060938714333,
a2=-0.9950718292249559
    
```

Note that the last line must not have a comma at the end. If the file has less than ten biquads, then only that number of biquads will be imported. For example, if importing a file with six biquads, the first six filters will be set, and the last four will not be changed. (Note: if the last line ends with a comma, that counts as an extra biquad.)

If the file contains more than ten biquads, then an error will be reported and no filters will be changed.

Crossover advanced mode

The **Crossover** blocks have eight biquads for each output channel. In **Advanced** mode, all eight biquads need to be specified. After pasting in the coefficients, click on the **Process** button for them to take effect.

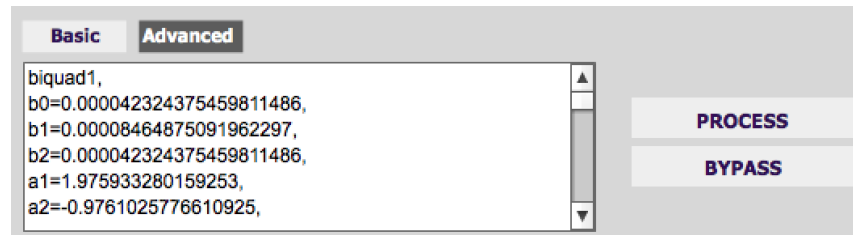

9.4.3 Biquad design software

Following are programs that can be used to design your biquad coefficients.

9.4.3.1 Biquad calculation spreadsheet

The community-developed biquad calculation spreadsheet allows many filter types to be calculated, including notch filters, Linkwitz transforms, and filters with arbitrary Q-factor. Access this spreadsheet here (requires Microsoft Excel):

- http://www.minidsp.com/images/fbfiles/files/All_digital_coefs_v1-20101026.zip

9.4.3.2 Room EQ Wizard (REW)

Room EQ Wizard is a free acoustic measurement and analysis tool, available for Windows, Mac and Linux platforms. It includes the ability to automatically generate a bank of parametric EQ biquads based on a measurement. These coefficients can be saved to a file from REW and loaded directly into a PEQ bank in a miniDSP plugin. Room EQ Wizard can be downloaded here:

- <http://www.roomeqwizard.com/#downloads>

For guidance on using this feature, please refer to the app note [Auto EQ with REW](#).

9.5 WORKING WITH CONFIGURATIONS

The data that controls the audio processing is called a *configuration*. The processor stores four configuration presets in its internal memory, which can be selected from the plugin or via remote control.

9.5.1 Online and offline mode

Initially, the plugin is *offline*. When the **Connect&Synchronize** button is used, the plugin downloads configuration data into the processor and goes *online*. Changes made in the plugin user interface therefore fall into two categories:

The plugin is online

The plugin user interface is “live” – that is, any changes made to the audio processing parameters in the user interface are immediately downloaded to the processor. The effect of these changes will thus be audible as the changes are made.

The plugin is offline

Changes made to audio processing parameters in the plugin user interface will be made locally only. The next time the plugin goes online, these parameters will be downloaded to the processor (as long as the **Synchronize Config** button is selected).



The configuration contained in the miniDSP hardware unit cannot be uploaded back to the computer. Therefore, you **must** save your configuration to a file if you wish to recover from any changes you make while offline.

9.5.2 Selecting a configuration

The active configuration is selected by one of the four Configuration Selection buttons:



To switch to a different configuration, click on a different button. There are two cases:

The plugin is online

Audio processing will switch to the parameters of the selected configuration. If, however, parameters of the selected configuration have been changed since the last time that configuration was synchronized, then a dialog will appear asking you if you want to synchronize the configuration.

The plugin is offline

The user interface will update to show the parameters of the newly selected configuration. If this configuration is changed in the user interface, it will be downloaded to the processor the next time it is synchronized.

9.5.3 Saving and loading configurations

Configurations can be saved to and loaded from files. Each configuration is stored in a separate file. It is *very* strongly recommended that each configuration programmed into the processor be saved to a file, to ensure that the configuration is not lost if the processor is inadvertently reset.

To save the currently selected configuration to a file, drop down the File menu, then select **Save** and then **Save current configuration**. In the file box, select a location and name of the file, and save it.

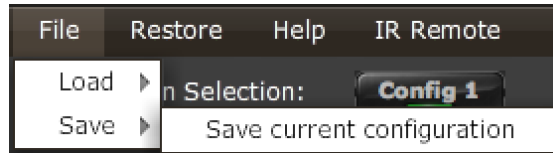

To load a configuration, first select the configuration preset that you wish to load into. Then drop down the File menu, select **Load**, and then **Load configuration to current slot**.

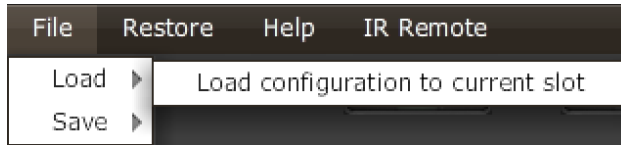

If the plugin is online, the new configuration data will be downloaded to the processor immediately. If the plugin is offline, the data will be loaded into the user interface only, and will be downloaded to the processor the next time it is synchronized.



To copy a configuration from one preset to another, save the configuration to a file, then select a different configuration preset and load the file.

9.5.4 Relationship with Dirac Live

Each configuration preset in the DDRC-24 plugin corresponds to the same-numbered filter set configured in Dirac Live Calibration Tool. For example, if the remote control or front panel is used to select preset 3, then both DDRC-24 configuration 3 and Dirac Live filter set 3 are loaded for audio processing.

The stored configuration file contains the data for the DDRC-24 plugin only. The Dirac Live filters must be loaded separately using **Dirac Live Calibration Tool for miniDSP**.



9.5.5 Restoring to defaults

Configurations can be reset to the factory defaults from the Restore menu. There are two options:

Factory Default

Reset all four configuration presets to the factory default settings.

Current Configuration Only

Reset only the currently selected configuration preset to the factory default settings.

If the plugin is online, the configuration data on the processor (all or just one configuration, as selected) will also be reset to factory defaults. Otherwise, the reset will take place in the user interface only, and the new configuration data will be downloaded to the processor next time it is synchronized.

9.6 KEYBOARD SHORTCUTS

The **DDRC-24** plugin supports the use of the keyboard for many operations.

Tab

The Tab key moves the focus from the current user interface element to the next. A blue-grey surrounding box usually indicates the user interface element with the focus. Shift-Tab moves the focus in the opposite direction.

Up/down arrows

The up/down arrow keys (and in some cases, the left/right arrow keys) adjust the value of many parameters, if they have the focus:

- Gain adjustment
- Crossover frequency and filter type
- PEQ filter frequency, gain, and Q

Space

The Space bar toggles buttons that have two states, such as **Bypass**, **Invert**, and **Mute**, if they have the focus.

10 ADDITIONAL INFORMATION

10.1 SPECIFICATIONS

Computer connectivity	Driverless USB 2.0 control interface for Windows and Mac OS X
USB audio input and output	XMOS asynchronous USB audio, 44.1 to 192 kHz, USB Audio Class 2 compliant. ASIO driver for Windows, driverless for Mac OS X.
Digital audio Input	TOSLINK optical. A high quality onboard Asynchronous Sample Rate Converter ensures compatibility with most sample rates, from 20–216kHz.
Analog audio inputs	Unbalanced stereo (2 channels) analog audio on RCA connectors <ul style="list-style-type: none"> - Max input of 4V or 2V RMS, jumper-selectable - Input impedance: 10kΩ - THD+N: 0.003% (RCA to USB) - Dynamic range: 102dB
Analog audio outputs	Unbalanced analog audio (4 channels) on RCA connectors <ul style="list-style-type: none"> - Max output: 2V RMS - Output impedance: 560Ω - THD+N: 0.001% (USB to RCA) - Dynamic range: 103dB
Audio resolution	24-bit input and output resolution, 48 kHz internal sample rate
Audio processing	32-bit floating-point processor. Flexible matrix mixer, Dirac Live [®] , user-programmable IIR filtering, individual delays and gains per channel.
Filtering capabilities	Dirac Live mixed-phase filtering, implemented with Dirac Live Calibration tool for miniDSP. User-programmable IIR filters: high pass and low pass crossover filters up to 48 dB/octave per output channel; ten biquad filters (parametric) EQ per output channel – peaking, low-shelf, and high-shelf types.
Storage/presets	All output channel settings controllable in real time from software user interface. 4 onboard presets stored in local flash memory.
Infrared remote	“Learning remote” capabilities (NEC, Philips, Sony)
Power supply	12 VDC single supply @ 300mA, 2.1 mm center-positive
Dimensions (H x W x D)	27 x 119 x 107 mm

10.2 FIRMWARE UPGRADE

miniDSP may occasionally provide an upgrade to the DDRC-24 MCU firmware to enable new features. To upgrade the MCU firmware, first download and install the latest version of the DDRC-24 plugin from the **User Downloads** section of the miniDSP website.



DO NOT DISCONNECT THE USB CABLE OR POWER FROM THE *DDRC-24* WHILE FIRMWARE UPGRADE IS IN PROGRESS. DOING SO MAY “BRICK” YOUR *DDRC-24*.

10.2.1 Windows

1. Connect the DDRC-24 to your computer via USB (if not already connected) and power it on.
2. Start the **miniDSP UAC2 DFU Tool**.

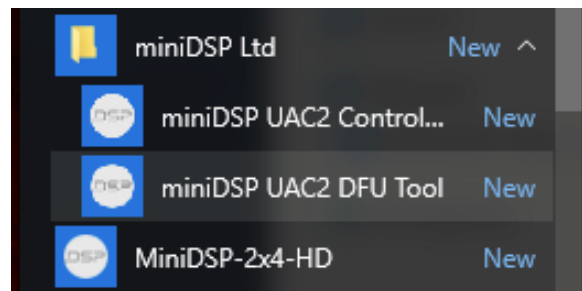

3. The upgrade program will start:

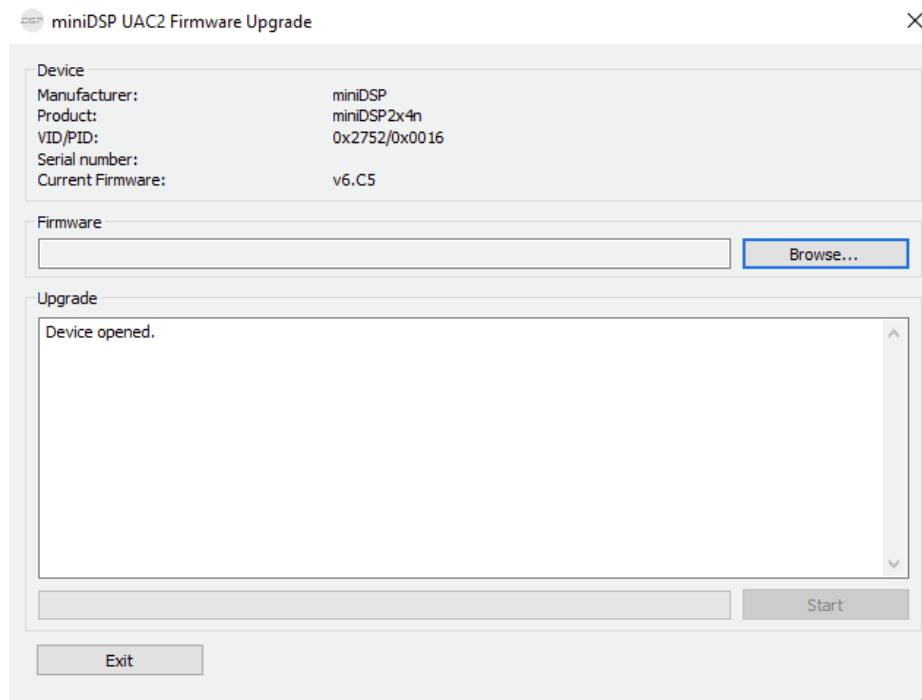

- Click on the **Browse** button, navigate to the folder **XMOS_Firmware** in the plugin download folder, and select the firmware file. It will have a name like “DDRC-24_XMOS_v1.5.bin.” (The version number “v1.5” may change.)
- Click on the **Start** button.
- You will get a progress bar as upgrade proceeds:

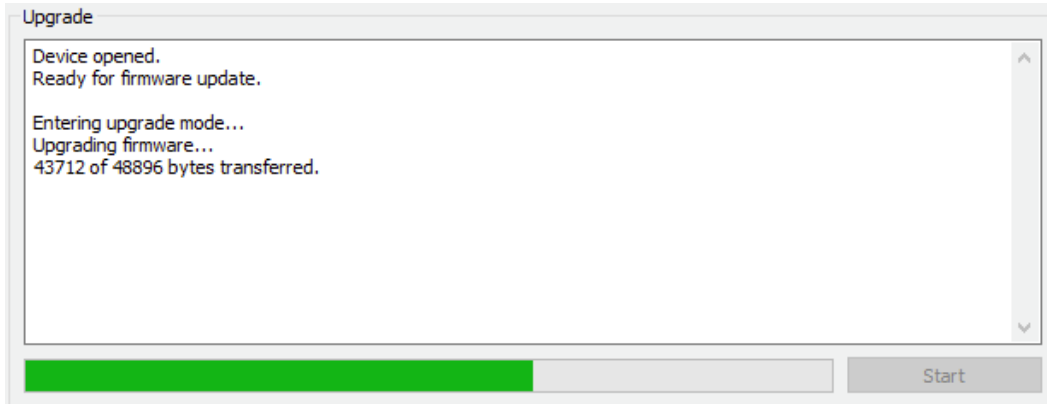

- Once the firmware upgrade completes, you will see a message that the upgrade completed successfully:

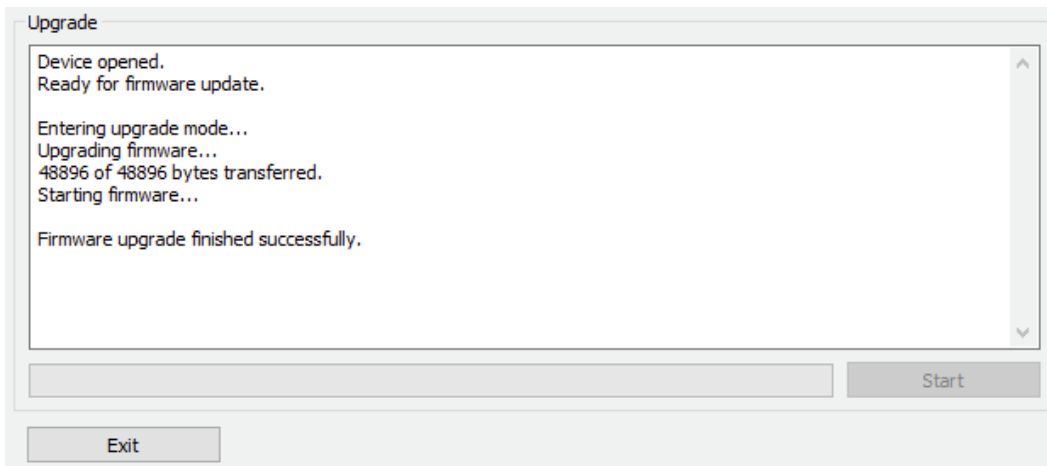

- Click on **Exit**.
- That’s it! You’re done. You can now use your DDRC-24 with the new functionality.

10.2.2 Mac OS X

To load firmware using Mac OS X requires that you use the Terminal program (located in the Applications/Utilities folder). In the examples that follow, black text is the “prompt” printed by Terminal, blue text is text typed in by you, and red text is the program output.



It is important that you type exactly as shown including characters like “.” and “/” where noted. Press the Tab key after typing the first two characters of any filename, to activate auto-completion.

Download the latest software for the DDRC-24 from the User Downloads area of the minidsp.com website. Double-click on it to unzip it. Assuming that you have placed it into the Downloads folder on your Mac, you will then type:

```
mac:~ me$ cd Downloads/DDRC_24_v1_0/XMOS_Firmware/  
mac:XMOS_Firmware me $ ls  
DDRC-24_XMOS_v1.5.bin  miniDSP_UAC2_DFU_OSX      readme.txt  
mac: XMOS_Firmware me $
```

You see in the above list the name of the firmware file, **DDRC-24_XMOS_v1.5.bin** (the version number “v1.5” may change). Now change to the folder holding the actual firmware upgrade tool, and then run it:

```
mac:XMOS_Firmware me$ cd miniDSP_UAC2_DFU_OSX/  
mac:miniDSP_UAC2_DFU_OSX me $ source setup.sh  
mac:miniDSP_UAC2_DFU_OSX me $ ./xmosdfu --download ../DDRC-24_XMOS_v1.5.bin  
VID = 0x5ac, PID = 0x8007, BCDDevice: 0x300  
VID = 0x5ac, PID = 0x8007, BCDDevice: 0x300  
...  
VID = 0x2752, PID = 0x11, BCDDevice: 0x6e0  
XMOS DFU application started - Interface 3 claimed  
Detaching device from application mode.  
Waiting for device to restart and enter DFU mode...  
VID = 0x5ac, PID = 0x8007, BCDDevice: 0x300  
VID = 0x5ac, PID = 0x8007, BCDDevice: 0x300  
...  
VID = 0x2752, PID = 0x11, BCDDevice: 0x6e0  
... DFU firmware upgrade device opened  
... Downloading image (../DDRC-24_XMOS_v1.5.bin) to device  
... Download complete  
... Returning device to application mode  
mac:miniDSP_UAC2_DFU_OSX me $
```

You can now proceed to use the DDRC-24 as normal.

10.3 TROUBLESHOOTING

The following table lists the most common causes of issues. If following this table does not provide a solution, see [Obtaining Support](#).

DDRC-24 plugin

1	Cannot install software	a. Confirm that you downloaded and installed the required frameworks first (see Software Installation).
2	DDRC-24 plugin running in background but not showing	a. The Adobe Air environment may need a network connection the first time you run a plugin. Close the plugin program, ensure that your computer has a network connection, and restart the plugin. b. The Adobe Air environment may require a version update. Download the latest version from http://get.adobe.com/air/ .
3	DDRC-24 plugin cannot connect	a. Check that the USB cable to the DDRC-24 is firmly connected b. Reset the processor by power-cycling the unit.
4	No signal showing on input meters in DDRC-24 plugin	a. Check the cabling from your source. b. Check that your source is playing audio and that it is not muted or have volume control turned down. c. Check that the plugin is synchronized with the hardware unit.
5	Low audio on outputs	a. Check the cabling from the processor to your amplifiers. b. Check that your amplifiers are turned on and that any volume controls are turned up. c. Check that the input and output meters are showing signal. d. Check that master mute is not enabled. e. Check the master volume level. f. Check that your crossover frequencies are correct e.g. that you don't have high pass and low pass frequencies incorrectly set. g. Check that the matrix mixer is sending the correct inputs to the correct outputs.
6	Audio sounds distorted	a. Check the output meter and ensure that you are not overloading the outputs. If necessary, reduce the output gain and/or the amount of boost in the EQ blocks.
7	Audio is coming through the wrong outputs	a. Check the cabling from the processor to your amplifiers. b. Check that you have correctly set up the matrix mixer to send the correct inputs to the correct outputs.
8	Cannot reload a configuration	a. Confirm the file format of your file (.xml). b. Confirm the version of the file.

Dirac Live Calibration Tool

1	The DDRC-24 doesn't appear in the Sound System tab	<ol style="list-style-type: none"> a. Check that the USB cable to the DDRC-24 is firmly connected. b. Check that you do not have any other program running that is attempting to communicate with the DDRC-24, such as the DDRC-24 plugin. c. Check that you have the miniDSP version of the software installed, called Dirac Live Calibration Tool For miniDSP. d. Go to the Sound System tab and click the Rescan button.
2	The measurement test signal produces no output	<ol style="list-style-type: none"> a. Ensure that the DDRC-24 processor is connected correctly into the audio system. b. Check that the downstream amplification is powered on. c. Check that the downstream amplification is not muted and doesn't have gain/trim controls set to zero. d. Quit DLCT, open the DDRC-24 plug and click connect. Connect an analog source to the inputs, and confirm that signal levels are seen on input and output meters.
3	No input from measurement microphone	<ol style="list-style-type: none"> a. Check that the USB cable to the UMIK-1 is securely seated. b. Check that the UMIK-1 is selected in the Mic Config tab. c. Remove any USB hubs and extensions.
4	Insufficient recording level	<ol style="list-style-type: none"> a. Increase microphone level in the Output & Levels tab. b. Go to the Control Panel and view the Recording tab of the Sound pane. Select the UMIK-1 and view its Properties. In Levels, set the gain to 100. c. Increase system output volume.
5	Unable to generate correction filters (Optimize button)	<ol style="list-style-type: none"> a. Check that your computer is connected to the Internet and able to pass HTTP (web) traffic. b. Check that you do not have any other program running that is attempting to communicate with the DDRC-24, such as the DDRC-24 plugin.

10.4 OBTAINING SUPPORT

1. Check the forums on minidsp.com to see if this issue has already been raised and a solution provided.
2. Contact miniDSP via the support portal at minidsp.desk.com with:
 - a. The product information obtained from the DDRC-24 plugin's About button and Dirac Live Calibration Tool for miniDSP on the Sound System tab.
 - b. A clear explanation of the symptoms you are seeing.
 - c. A description of troubleshooting steps (see [Troubleshooting](#)) performed and your results.